



BUILDING TECHNOLOGY VALVES AND SYSTEMS

Drinking water hygiene and corrosion resistance
without compromise

KEMPER
DRIVING PROGRESS

A photograph of three construction workers on a site. The worker in the center is wearing a yellow hard hat and a grey t-shirt, pointing upwards with a pencil. The worker on the left is wearing a white hard hat and a light blue button-down shirt, holding a rolled-up blueprint. The worker on the right is wearing a white hard hat and a plaid shirt. They are standing in front of a concrete structure with scaffolding. Two yellow diagonal lines are overlaid on the image, one pointing towards the top left and the other towards the bottom left.

VALVES AND SYSTEMS
FOR MAINTAINING
DRINKING WATER HYGIENE

CONTENTS

04 - 05	Gunmetal as a material
06 - 11	Stop valves
12 - 23	Backflow prevention
24 - 27	Safety valves
28 - 29	Pressure reducing valves and filters
30 - 33	Balancing valves
34 - 37	Measuring products
38 - 41	Flush-mounted solutions
42 - 49	Frost-proof outdoor taps
50 - 51	TRESOR wall cabinets
52 - 55	Sampling valves
56 - 57	Insulation shells
58 - 71	Hygiene system KHS
72 - 73	Thermal separator
74 - 83	ThermoSystem KTS
84 - 85	Dendrit <i>STUDIO</i>
86	Service contacts

GUNMETAL AS A MATERIAL

SOPHISTICATED CASTING MADE OF COPPER ALLOYS

In Europe, gunmetal can be used in drinking water without limitation.



Classic gunmetal consists of a copper-tin-zinc-lead alloy (CuSn5Zn5Pb2) and has proved itself with its high level of corrosion-resistance in drinking water installations. The element contents of lead (Pb) and nickel (Ni) satisfy the specifications of DIN 50930-6 and are limited such that the material meets the requirements of the Drinking Water Directive. Series of tests in laboratories accredited according to German and European standards and decades-long use in the field of drinking water have duly confirmed these results in recent years.

Gunmetal is:

- // immune to dezincification thanks to its high Cu content
- // usable in all situations for all water qualities in accordance with the German Drinking Water Directive
- // usable without restriction in accordance with the DIN/DVGW Rules concerning drinking water
- // particularly corrosion-resistant
- // recycled material and is manufactured from old valves and components without quality loss, thus protecting the environment and resources

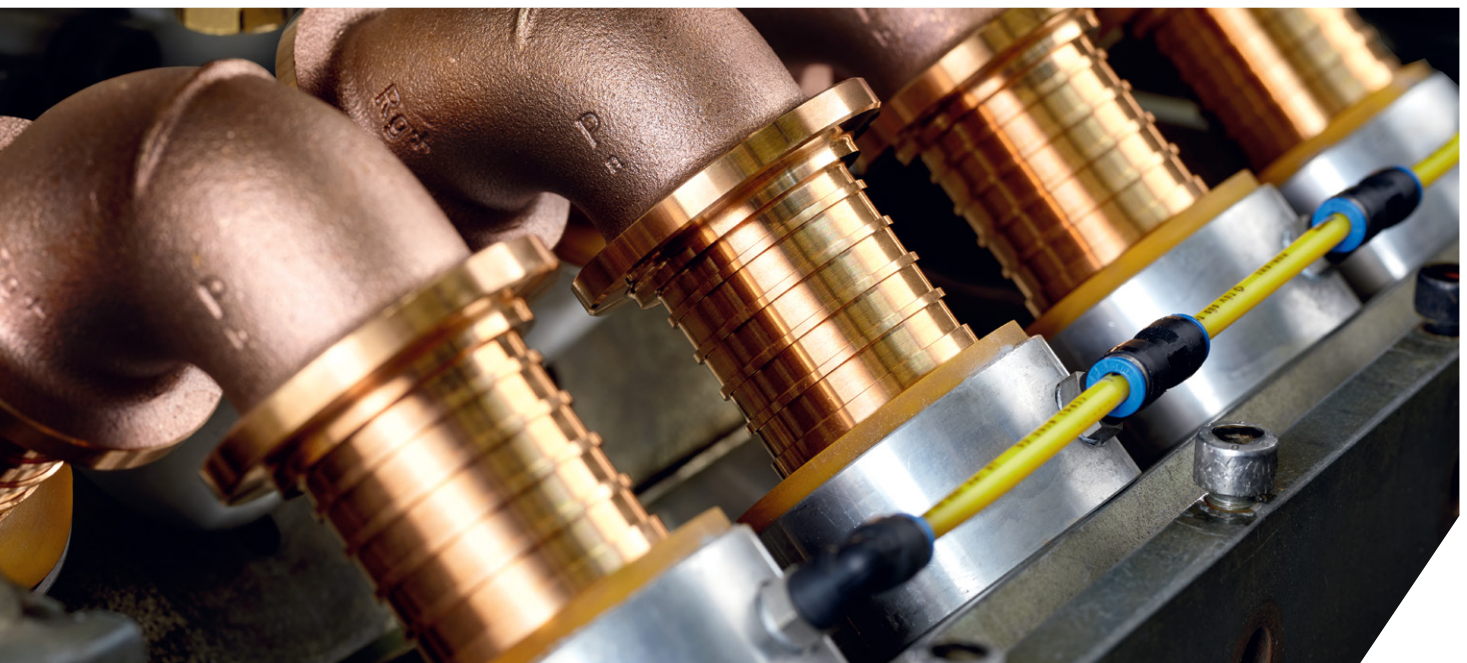



Our new alloy: Rg+

Less is sometimes more. As with our new lead-free alloy Rg+. This is a real milestone which further promotes health and safety and has less environmental impact. All this is achieved while maintaining its outstanding characteristics.

Benefits at a glance

- // Mechanical characteristics identical to Rg5
- // Suitable as an unrestricted press connector
- // Existing components for Rg5 can be cast in Rg+
- // High level of corrosion-resistance and long service life (formation of cover layer)
- // High degree of design freedom
- // No risk of stress crack corrosion
- // No cold brittleness (can be used up to -176°C)
- // Fulfils RoHS and REACH

A "lead-free" future: A change in legislation is on the horizon.

This change will mean the use of lead in materials will be banned, as is already the case in the automobile industry and in many consumer goods. Lead itself does not affect corrosion-resistance but rather is necessary to produce components that are made of the material. If this element is missing, classic gunmetal cannot be processed.

In order to meet the legislative and constantly rising hygiene requirements, KEMPER developed a lead-free gunmetal in-house, which is built up from the basic structure of the lead-containing gunmetal CuSn5Zn5Pb2 . In the lead-free gunmetal, lead is only present in a permissible content of 0.10% as an unavoidable trace element and is no longer an intended alloy component.

And even so, the basic properties like corrosion-resistance, stability, stretch, hardness, processability and machineability of the modification are not impacted upon. The material has already been accepted into the positive list of the Umweltbundesamt (UBA-German Environmental Agency) and may be used without limitation in accordance with the Drinking Water Directive. The lead-free gunmetal not only covers these future material requirements in the field of hygiene but also already fulfils the requirements of the REACH and RoHS directives.

STOP VALVES

KEMPER STOP VALVES – ALWAYS ONE IDEA AHEAD

Stop valves – an essential component of any domestic water installation, which must function perfectly in the event of maintenance or malfunctions of the installation. The **WESER** series has proved itself to be a leading innovator, boasting an extensive offering of outstanding design features for over 50 years.

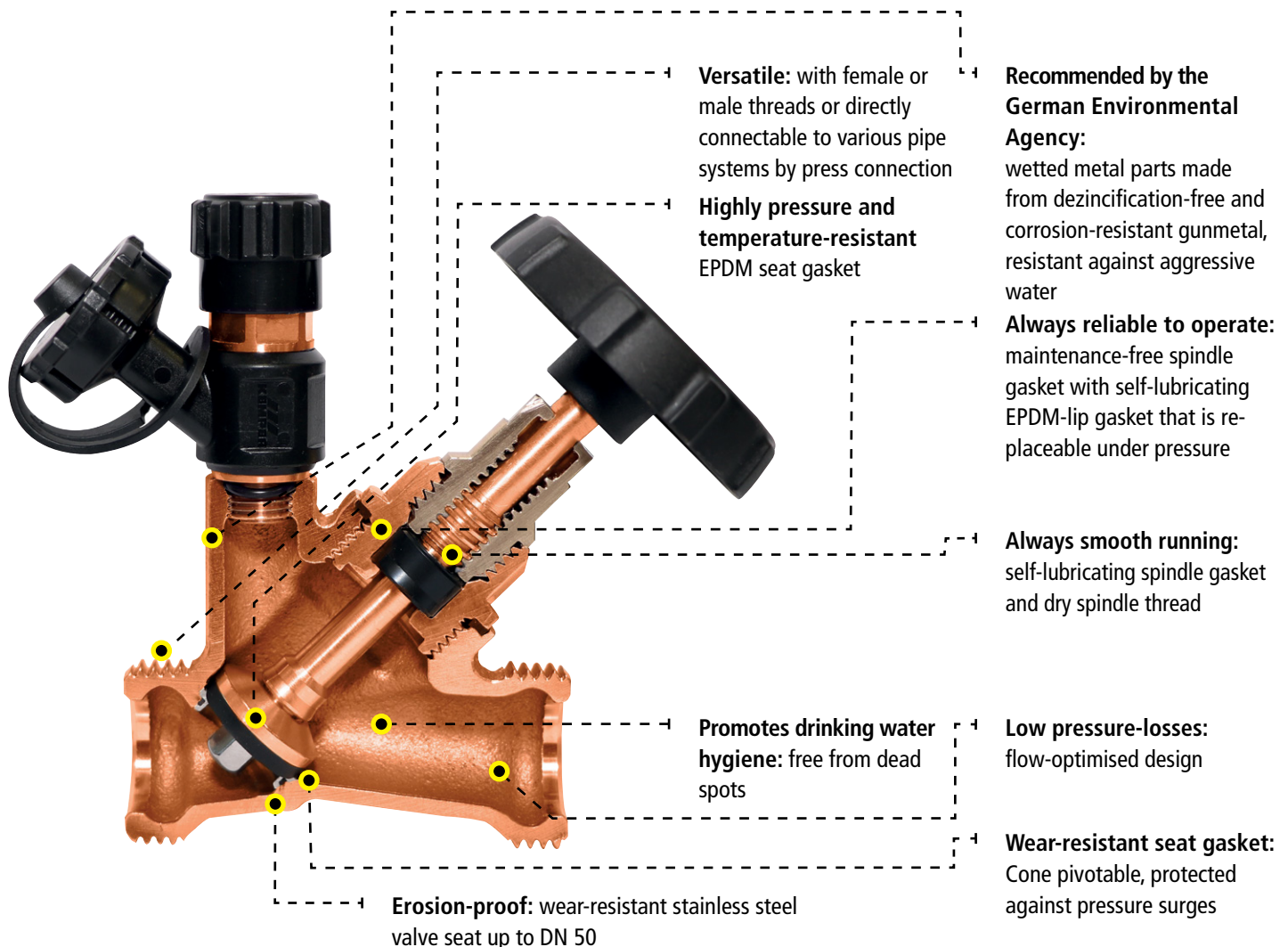

CHRONOLOGY OF A TRENDSETTER

1971



First drinking water stop valve made of gunmetal

1982

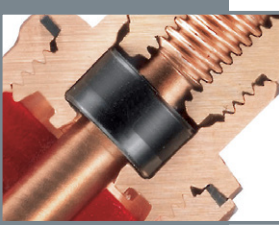

Market innovation: valve free from dead spots with maintenance free spindle gasket

FREE OF DEAD SPOTS

2004



Use of stainless steel valve seat

2006



Market innovation: spindle gasket can be replaced under full system pressure

2007



Introduction of 10-year warranty for Figure 173

2012



10-year warranty is extended to cover the complete WESER series

2016



Simplified arrangement through switchover to a uniform housing model (with and without drain)

2021



Beginning of switchover to lead-free gunmetal alloy Rg+

THE SERIES:



WESER stop valve – Made entirely of gunmetal, maintenance-free

Benefits at a glance

- // Operation is highly reliable as spindle gasket can be replaced under full operating pressure
- // Permanently leakproof thanks to stainless steel valve seat
- // Long service life thanks to pivoted cone
- // Easy to operate and always smooth running thanks to self-lubricating spindle gasket



WESER stop valve, with plugged drain port, MPT, Figure 173 2G



WESER stop valve, with plugged drain port, FPT, Figure 190 02

Series overview:

	Figure no.
WESER stop valve, with plugged drain port, MPT	173 2G
WESER stop valve, with plugged drain port, FPT	190 02
WESER stop valve, without plugged drain port, FPT	190 00
WESER free-flow stop valve, with plugged drain port, with permanently integrated MAPRESS press connection	190 22
WESER stop valve, with plugged drain port, with permanently integrated MEPLA press connection	190 40
WESER stop valve, with plugged drain port, with permanently integrated SANPRESS/PROFIPRESS press connection	190 30

**NIRO stop valve –
Made entirely of stainless steel,
for special applications**

Benefits at a glance

- // Long service life thanks to pivoted cone
- // Operation is highly reliable as spindle gasket can be replaced under full operating pressure
- // Easy to operate and always smooth running thanks to self-lubricating spindle gasket



NIRO stop valve, with drain, with permanently integrated MAPRESS press connection, Figure 073 01



NIRO stop valve, with drain, MPT, for stainless steel flat sealing fastenings, Figure 073 1G

Series overview:

Figure no.

NIRO stop valve, without plugged drain port, with permanently integrated MAPRESS press connection	073 00
NIRO stop valve, with plugged drain port, with permanently integrated MAPRESS press connection	073 01
NIRO stop valve, with plugged drain port, MPT, for stainless steel flat sealing fastenings	073 0G
NIRO stop valve, with plugged drain port, MPT, for stainless steel flat sealing fastenings	073 1G

**ECO stop valve –
made entirely of gunmetal
in the base version**

Benefits at a glance

- // Prevents bacterial growth by being free from dead spots
- // Corrosion-resistant as wetted metal parts are made of gunmetal
- // Temperature-resistant up to max. 110°C thanks to special EPDM seat gasket



ECO stop valve, with plugged drain port, MPT, Figure 170 2G



ECO stop valve, with plugged drain port, FPT, Figure 171 02

Series overview:

Figure no.

ECO stop valve, with plugged drain port, MPT	170 2G
ECO stop valve, with plugged drain port, FPT	171 02
ECO stop valve, with plugged drain port, with permanently integrated MAPRESS press connection	171 22
ECO stop valve, with plugged drain port, with permanently integrated SANPRESS/PROFIPRESS press connection	171 30



STANDARD stop valve – gunmetal valve with brass bonnet

Benefits at a glance

- // Prevents bacterial growth by being free from dead spots
- // Easy to operate and always smooth running thanks to self-lubricating spindle gasket
- // Temperature-resistant up to max. 110°C operating temperature thanks to special EPDM seat gasket



STANDARD stop valve, with plugged drain port, MPT, Figure 174 2G



STANDARD stop valve, with plugged drain port, FPT, Figure 191 02

Series overview:

STANDARD stop valve, with plugged drain port, MPT

Figure no.

174 2G

STANDARD stop valve, with plugged drain port, FPT

191 02



KHS quarter turn stop valve – gunmetal valve with full bore

Benefits at a glance

- // Low pressure-loss thanks to full bore
- // Corrosion-resistant thanks to gunmetal closing body
- // Maintenance-free thanks to removable inner top part



KHS quarter turn stop valve, FPT, Figure 385 00



KHS quarter turn stop valve, MPT, Figure 386 0G

Series overview:

KHS quarter turn stop valve, FPT

Figure no.

385 00

KHS quarter turn stop valve, MPT

386 0G



WESER flange stop valve – made entirely of gunmetal, maintenance-free up to DN 150



Benefits at a glance

- // Long service life thanks to pivoted cone
- // Easy to operate and always smooth running thanks to self-lubricating spindle gasket
- // Corrosion-resistant as wetted metal parts are made of gunmetal
- // Maintenance-free thanks to gaskets that can be removed under pressure up to DN 80



stop valve,
without drain valve, flanged,
Figure 135 01

stop valve,
with drain valve, flanged,
Figure 135 02

Series overview:

stop valve, without drain valve, flanged

Figure no.

135 01

stop valve, with drain valve, flanged

135 02

Selection table – All stop valves at a glance

Series	free from dead spots	maintenance-free	special seat gasket, high-pressure and temperature-resistant	pressure rating PN16	exact-fitted insulation shell optional	gunmetal in wetted area	valve seat made of stain- less steel (up to DN 50)	valve disc, pivoted	self-lubricating lip gasket	spindle gasket replaceable under pressure	10-year warranty
WESER	✓	✓	✓	✓	✓	✓	✓	✓	✓	✓	✓
NIRO	✓	✓	✓	✓	✓	✓	✓	✓	✓	✓	✓
ECO	✓	✓	✓	✓	✓	✓	✓	✓	✓	✓	✓
STANDARD	✓	✓	✓	✓	✓	✓	✓	✓	✓	✓	✓
quarter turn	✓	✓	✓	✓	✓	✓	✓	✓	✓	✓	✓
WESER Flange	✓	✓	✓	✓	✓	✓	✓	✓	✓	✓*	✓

*up to DN 80

BACKFLOW PREVENTION

ASSESS RISKS PROPERLY AND AVOID BACKFLOW

In most cases, a drinking water installation comprises several connections to other systems with more or less hazardous media. **DIN EN 1717** defines a uniform Europe-wide standard in the supply section "Drinking Water". This standard differentiates the areas of use for safety valves and defines fluid categories 1 to 5 according to the hazardous materials they contain. Therefore, an important criterion when selecting a safety

device is therefore the nature of the fluid whose backflow the drinking water should be protected from.

In addition to water suppliers, designers and plumbers are particularly exposed to an increased liability risk.

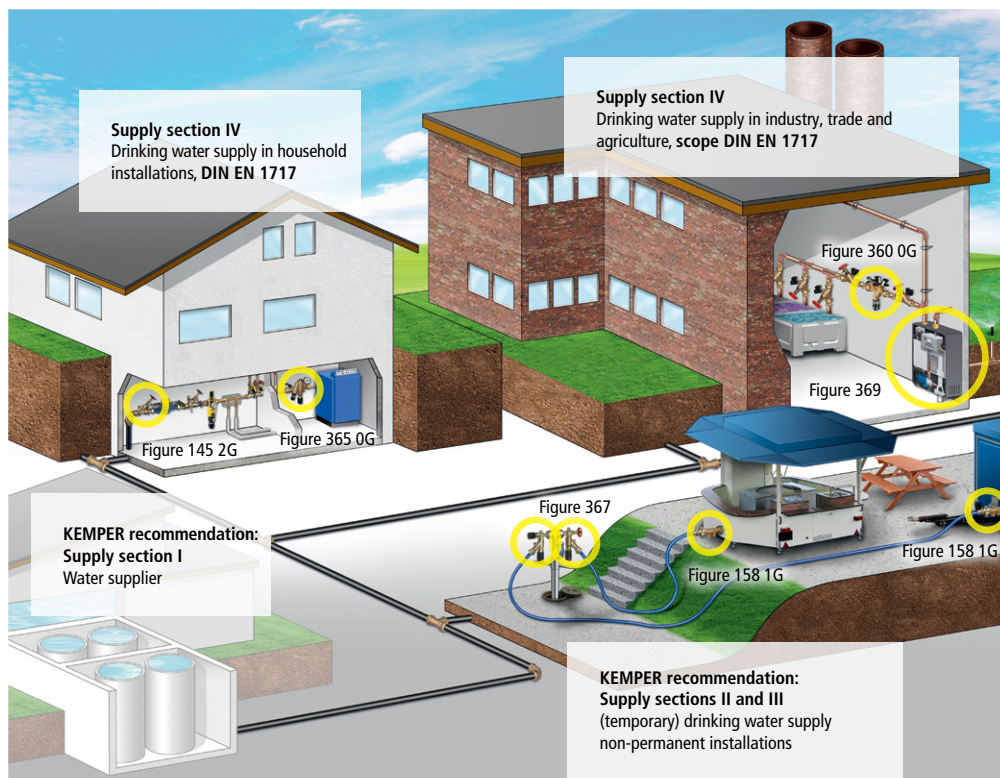

Definition of the fluid categories based on DIN EN 1717 ⁽¹⁾

<p>1 Fluid category 1</p> 	<p>Definition: Water intended for human consumption, taken directly from a drinking water installation.</p>	<p>Examples: // Drinking water, water under high pressure</p>
<p>2 Fluid category 2</p> 	<p>Definition: Fluid that does not represent a danger to human health. Fluids that are suitable for human consumption, including water from a drinking water installation, that may show a change in taste, smell, colour or temperature (heating or cooling).</p>	<p>Examples: // Coffee // tea // iron bacteria // cooled drinking water, steam (in contact with food) // sterile water // demineralised water // cooking food // treated drinking water ^(a)</p>
<p>3 Fluid category 3</p> 	<p>Definition: Fluid representing a health hazard due to the presence of one or more toxic or very toxic substances ^(b).</p>	<p>Examples: // Water for rinsing cutlery and kitchen utensils* // heating water without additives, toilet tank water* // water and surface-active substances ^{(b)*} // soft water (softening systems) ^{(b)*} // water and corrosion-protection agents ^{(b)*} // water and antifreeze ^{(b)*} // water and algaecides ^{(b)*} // water and detergents ^{(b)*} // water and disinfectants ^{(b)*} // water and coolants ^{(b)*} // washing fruit and vegetables ^(c) // (food establishments)</p>
<p>4 Fluid category 4</p> 	<p>Definition: Fluid that represents a health hazard for human beings through the presence of one or more toxic or very toxic substances or one or more radioactive, mutagenic or carcinogenic substances.</p>	<p>Examples: // E.g. hydrazine, lindane, insecticides</p>
<p>5 Fluid category 5</p> 	<p>Definition: Fluid that represents a health hazard for human beings through the presence of microbial or viral pathogens of infectious diseases (contamination, danger to life).</p>	<p>Examples: // Hepatitis viruses // salmonellae // coliform bacteria // washing machine water // swimming pool water // water for livestock watering // WC water</p>

(1) DIN EN 1717 Protection of drinking water from contamination in drinking water installations and general requirements for safety devices for preventing contamination of drinking water through backflow; German version EN 1717:2000; DVGW Technical Rules

(a) Treated drinking water within buildings (with the exception of the device)

(b) (b) Distinction between category 3 and 4 is, in principle, LD50 = 200 mg/kg body weight according to EU directive 93/92 of 23/04/1993

(c) Category 5 for pre-wash and wash water, Category 3 for rinsing water

* Possible higher category

2

Fluid category 2



Anti-pollution check valve EA

Benefits at a glance

- // The safety EA for narrow pipe networks thanks to opening pressure of just 10 hPa
- // Permanently leakproof thanks to stainless steel valve seat (Figure 145 2G)
- // Long service life thanks to pivoted shut-off stop cone (Figure 145 2G)
- // Outstanding operational safety as spindle gasket can be replaced under full operating pressure (Figure 145 2G)



Pass anti-pollution check valve,
Figure 158 1G



Free-flow combined stop and check
valve, Figure 145 2G

3

Fluid category 3



Backflow preventer, type CA

Benefits at a glance

- // With stainless steel mesh at inlet
- // Prevents bacteria growth by being free from dead spots
- // Corrosion-resistant as wetted metal parts are made of gunmetal



Backflow preventer, type CA,
Figure 362 2G

*In conjunction with shut-off device on the inlet side

4

Fluid category 4

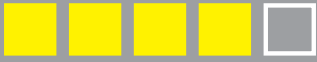

PROTECT RPZ backflow preventer type BA

Benefits at a glance

- // Maintenance-friendly thanks to three integrated test valves
- // With stainless steel mesh at inlet
- // Prevents bacteria growth by being free from dead spots
- // Corrosion-resistant as wetted components are made of gunmetal



The 3-chamber system

Technically sophisticated, and therefore reliable: The KEMPER PROTECT backflow preventer BA is based on a sophisticated three-chamber system with supply pressure, medium pressure and back pressure zones. The differential pressure controllers of the protection cartridge on the inlet side and the anti-pollution check valve on the outlet side ensure reliability and a high degree of security.



PROTECT backflow preventer type BA, Figure 360 01

PROTECT RPZ backflow preventer, type BA, flange connection

Benefits at a glance

- // Large water installations protected up to DN 150
- // Prevents bacteria growth by being free from dead spots
- // Corrosion-resistant as wetted metal parts are made of stainless steel



PROTECT RPZ backflow preventer, type BA, flange connection, Figure 361 01

*In conjunction with shutoff device on the inlet and outlet sides

**Dirt trap required in the inlet side

4

Fluid category 4

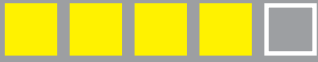

FK-4 RPZ outlet valve, type BA,
Fig. 367 01 015/020

FK-4 RPZ outlet valve type BA

The FK-4 RPZ backflow preventer type BA for the protection of the drinking water installation up to fluid category 4 is manufactured from corrosion-resistant gunmetal.

Shutoff occurs upstream of the backflow preventer cartridge. This prevents water leakage when not in use. FK-4 is available in the dimensions DN 15, 20, 25 and 50.

Benefits at a glance

- // High-speed filling: up to 75% faster compared to standard manufacturers
- // Maintenance-friendly thanks to integrated stop function
- // Inseparable RPZ backflow preventer and outlet valve unit fulfil duty to ensure public safety
- // Corrosion-resistant medium as wetted metal parts are made of gunmetal

The European standard DIN EN 1717, under Section 5.3.2 Connections, states:

"All connections to the drinking water installation are regarded as permanent connections." This means that all protection devices against backflow, back pressure and siphon backflow must be designed as if there were a permanent connection. Valves with hose connections must be designed in such a way that the maximum expected protection case can be covered.

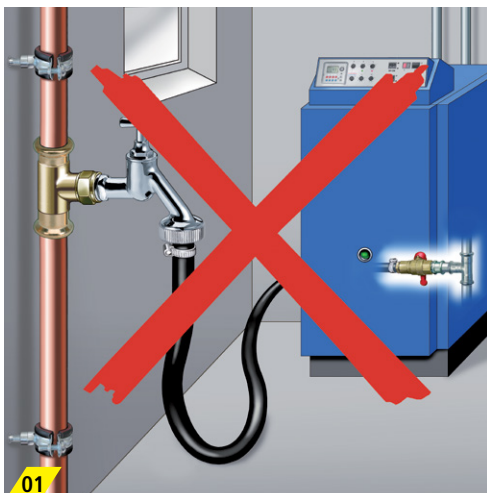

01 No longer permitted!¹⁾

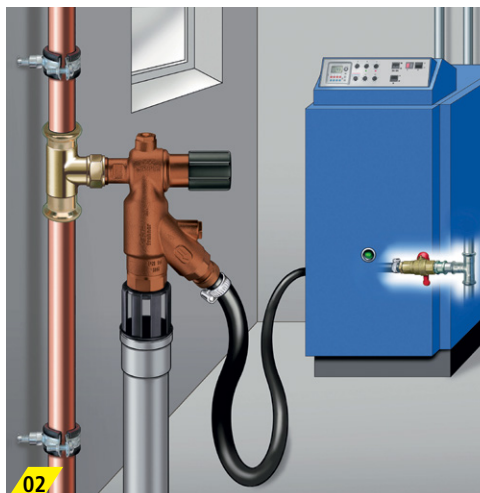

02 Standard-compliant solution

¹⁾ In new or old buildings if prior rights do not apply

KEMPER recommendation for use cases with protection against fluid category 4

01 Connection of chemical cleaning apparatus using KEMPER FK-4.

02 Connection of a coating device with KEMPER FK-4.

03 Connection of a drinks trolley with FK-4.

04 Connection of a mixing plant. Refilling with FK-4.

05 Connection of a high-pressure cleaner with/ without the addition of chemicals using FK-4.

06 Connection of a boot cleaning system with FK-4.



4

Fluid category 4

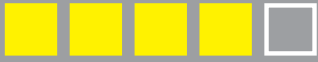

RPZ backflow preventer outlet for apartments type BA

Standard-compliant heating filling in apartments⁽¹⁾

Heating systems must be protected with an RPZ backflow preventer type BA for filling and refilling. This of course also applies to apartment heating systems!



The solution:

RPZ type BA for apartments allows heating systems in detached and semi-detached houses and apartment heating systems to be protected in line with the relevant standards. Visually, it blends in very well with the visible areas of bathrooms or kitchens thanks to its compact design. With its innovative wall fitting, it can easily be mounted in any installation situation.

01 RPZ type BA for apartments for topping up a gas-fired boiler in a bathroom

Benefits at a glance

- // Suitable for any installation situation thanks to innovative wall fitting
- // Protects the heating system from contamination with integrated stainless steel dirt trap
- // Design suitable for visible installation
- // Standard-compliant filling of decentralised/ apartment heating systems thanks to connectivity to any drop ear elbow



RPZ backflow preventer outlet for apartments type BA, Figure 368 02

⁽¹⁾ compliant with DIN EN 1717

4

Fluid category 4



FILL-MATIC

For filling the heating system, with comfort functions
FILL-MATIC 4 makes it easy and safe to fill and refill the heating system. The extremely compact valve combination permanently connects the drinking water installation with the heating system. The heart of the system is an RPZ backflow preventer type BA which uses proven cartridge technology and allows

systems to be protected up to fluid category 4. The integrated pressure reducing valve with dirt trap ensures a constant refilling pressure. The system is thus automatically filled up to the preset pressure. With the help of the downstream pressure gauge, you can keep an eye on the system pressure at all times.

Benefits at a glance

- // Constant refilling pressure through integrated pressure reducing valve with stainless steel dirt trap
- // Prevents bacteria growth by being free from dead spots
- // Corrosion-resistant as wetted components are made of gunmetal

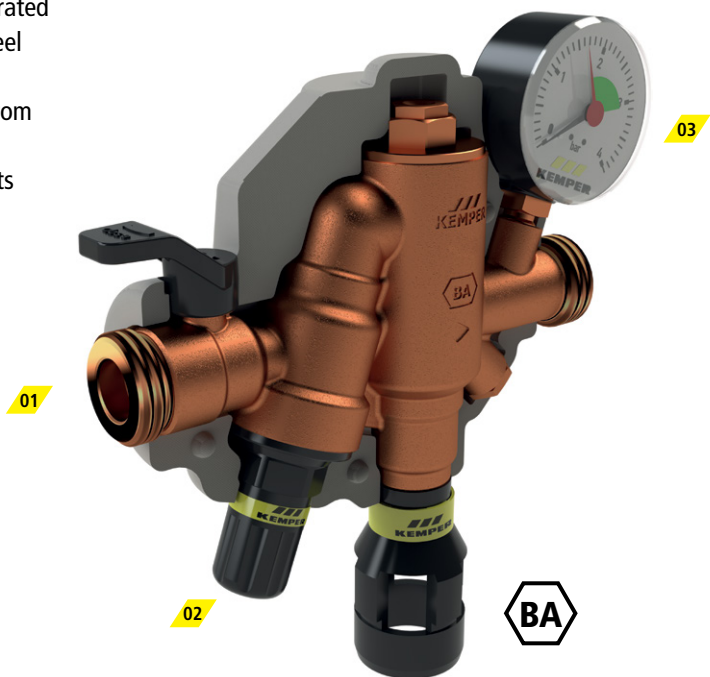

FILL-MATIC,
Figure 365 0G

01 Pressure reducing valve cartridge with integrated dirt trap

02 Shutoff

03 Manometer

4

Fluid category 4

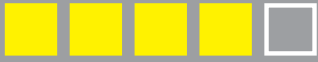

Benefits at a glance

- // For the prescribed annual maintenance according to DIN EN 806-5
- // For checking the safety and function of the RPZ backflow preventer according to DIN EN 12729
- // Suitable for carrying out maintenance for all safety valves in accordance with DIN EN 1717, in particular for all backflow preventers BA Figures. 360, 361, 367, 368 and heater filling combination Figure 365

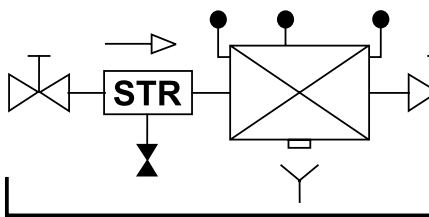

Protection device backflow preventer BA

Differential pressure measuring kit for RPZ backflow preventer type BA



Differential pressure measuring kit, Figure 360 99

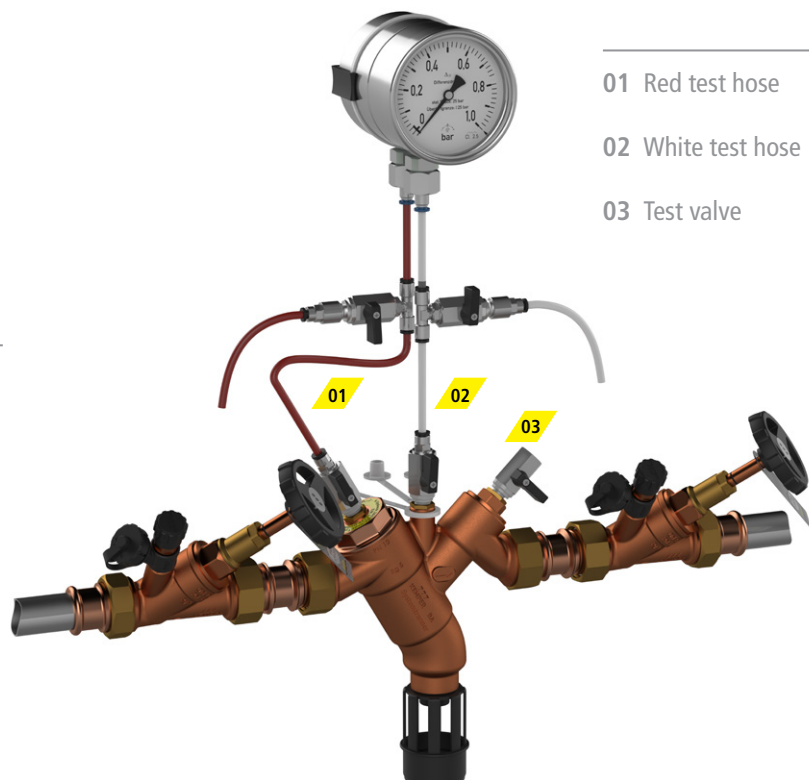

01 Red test hose

02 White test hose

03 Test valve

5

Fluid category 5



Fluid category 5 with the strictest requirements

Due to the significant risk to human health caused by category 5 fluids, indirect separation from the drinking water system must be ensured.

The FK-5 break tank station meets this requirement through an integrated free type "AB" drain. And it also has many functional highlights!

- // High performance: Flow rate up to 7 m³/h ¹⁾
- // Promotes drinking water hygiene through programmable flushing cycles for the drinking water feed pipe
- // Integrated tank cleaning programme
- // Controls operating time via weekly programme
- // Controls an external dosing or submersible pump
- // Reading of consumption and operating data using USB port
- // Fault signal output to BMS

¹⁾ In combination with the FK-5 water supply set plus, Figure 369 01

FK-5 break tank station

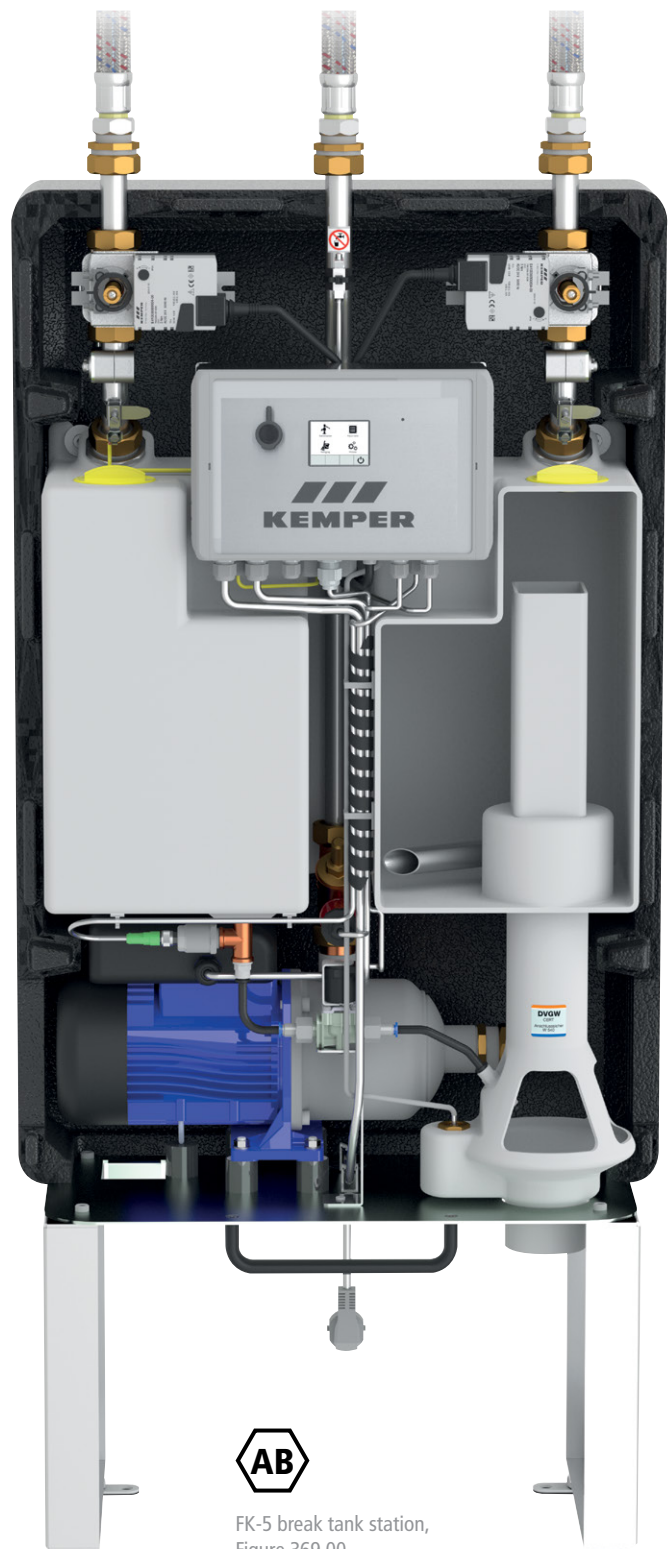

FK-5 break tank station,
Figure 369 00

5

Fluid category 5



Product features of the FK-5 break tank station

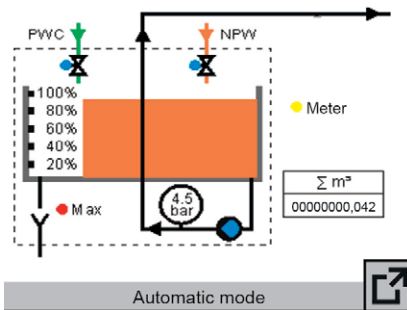

Convenient use of a wide range of functions
Touch screen control beneficial to operation.

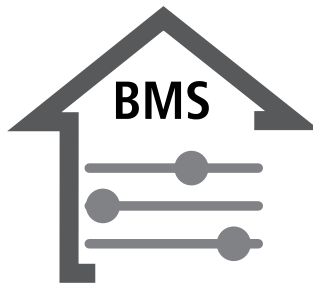

BMS link
Dry contact is provided for outputting a fault message to the BMS.

Consumption data	
24 hours	
12 days	
3 months	
6 months	
1 year	
↗	↑ ↓ OK

Know what's happening
Data storage for building management.



Overcome heads, supply volumes
Wide range of services for many application areas. Example: Irrigation with high volume flow.

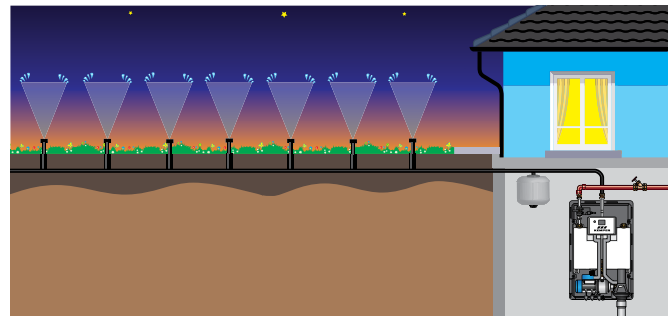
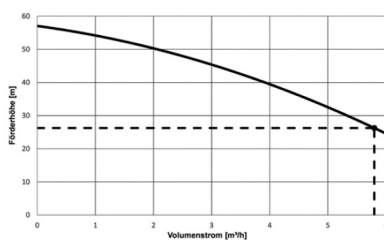

NOTE: We recommend installing an expansion vessel in the pressure pipe to avoid frequent cycling of the system.

Automated operation, vandalism prevention
Usage optimisation with time control and operating time selection.

Automatic flushing inlet 1			
Monday	off	00:00	0 min
Tuesday	off	00:00	0 min
Wednesday	off	00:00	0 min
Thursday	off	00:00	0 min
Friday	off	00:00	0 min
Saturday	off	00:00	0 min
Sunday	off	00:00	0 min
↗	↑ ↓ OK		

KEMPER recommendation for use cases with protection against liquid category 5

- 01 Water playground with source outlets
- 02 Underground s irrigation
- 03 Drinking troughs
- 04 Cooling towers
- 05 Roof greening

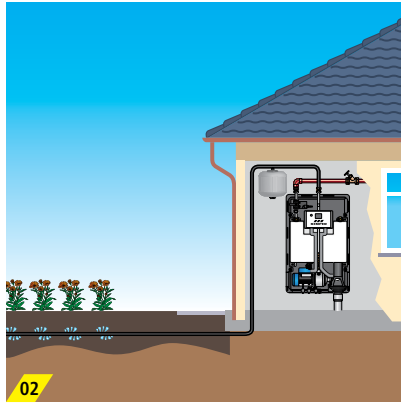

Enhancement options and optional accessories



FK-5 water supply set plus, Figure 369 01



FK-5 tank cleaning unit, Figure 369 02



Overflow monitoring for FK-5, Figure 369 04



FK-5 rack, Figure 369 03



FK-5 connection set Figure 369 27

SAFETY VALVES

LEAK DETECTION SYSTEM AND SAFETY GROUP

To protect drinking water installations from overpressure and avoid potential water damage, corresponding systems or safety valves provide the necessary monitoring and shutoff features.

Costly water damage can be consistently avoided with the leak detection system and safety group.

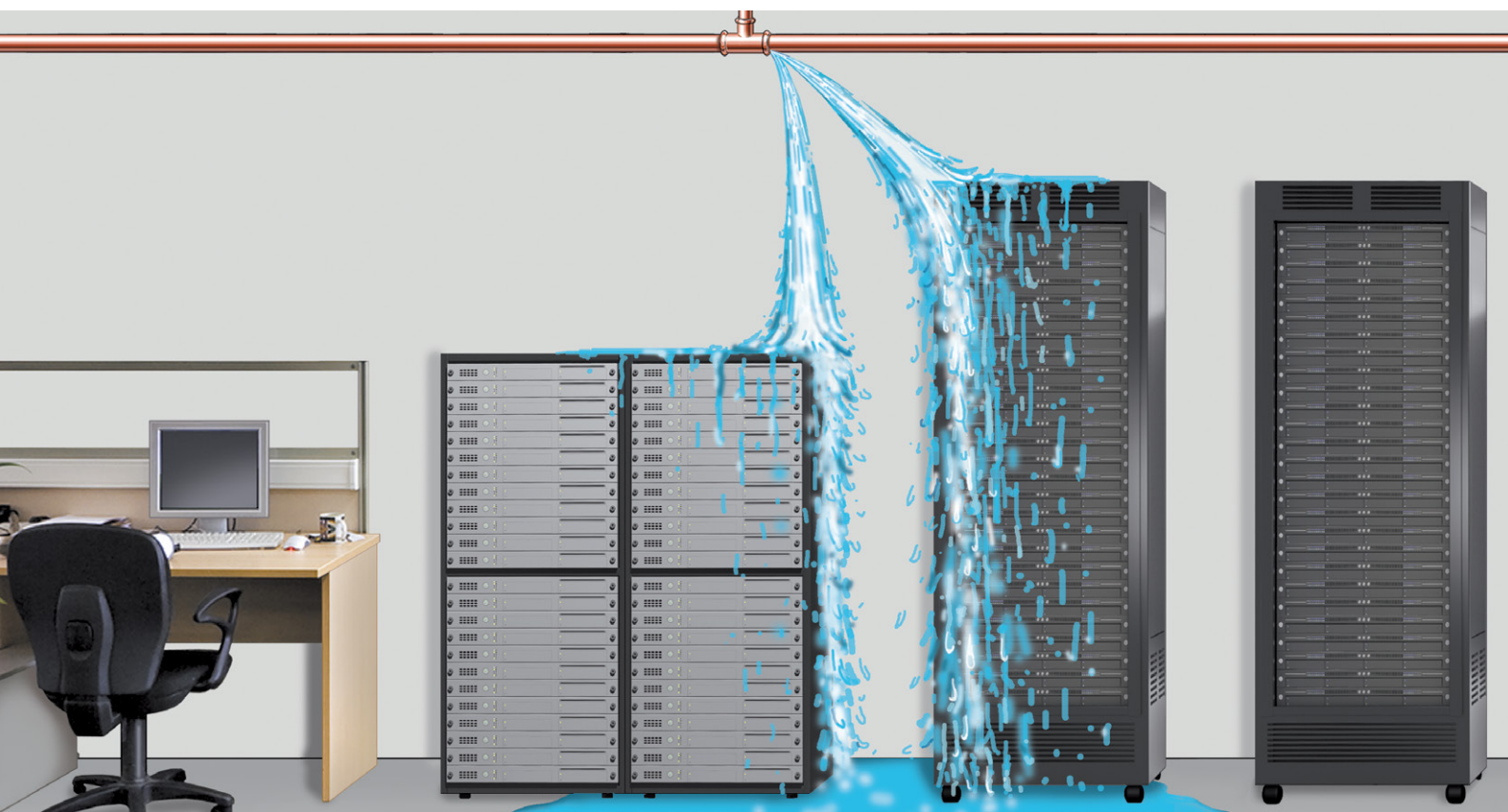



Leak detection system

Water damage due to leaks in drinking water systems can cause enormous damage. Installations or supply lines are to be considered as critical components, since they can create a risk of flooding. A leak may lead to the destruction of highly sensitive fixtures, e.g. in computer rooms and archives. The interruption of operation on business premises can also mean a loss of customers. Data loss and spending time re-commissioning are very costly. If intangible assets are affected in the private sector, the personal loss is usually irreparable. In property which is used seasonally (e.g. holiday apartments) and left unattended for long periods of time, leaks can lead to serious damage.

An overview of the options

Option 1: Leak monitoring

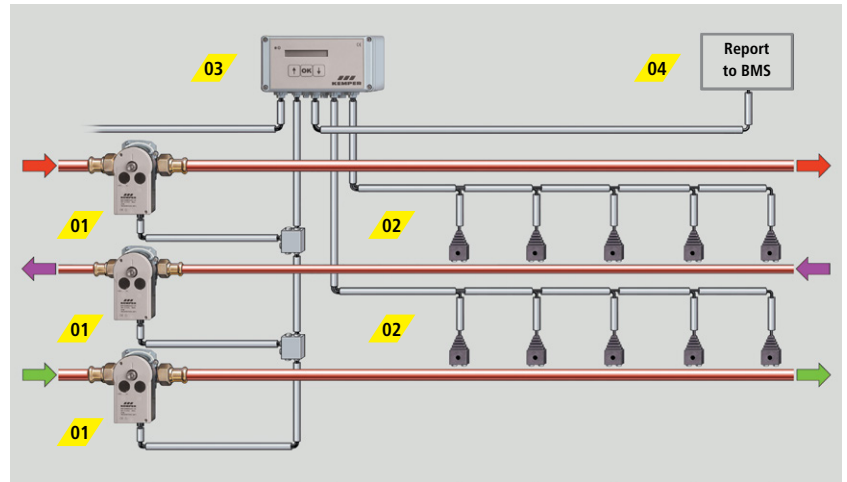

- 01 KHS quarter turn stop valve with actuator (up to max. 10 units)
- 02 Max. 50 water sensors with up to 2 possible detection circuits (max. 25 water sensors each per detection circuit)
- 03 Leakage control system
- 04 Forwarding of alarm, e.g. from the connection room or roof technical plant area with hot water heating to BMS

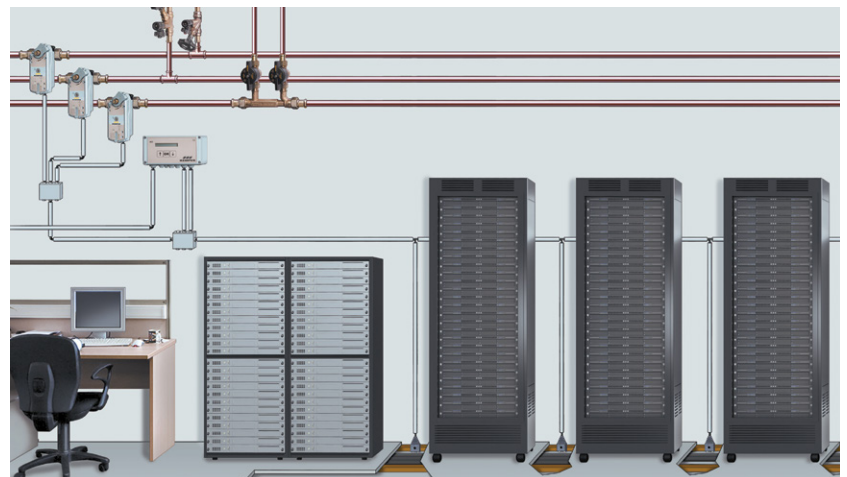

Example server room

Three KHS PLUS quarter turn stop valves are connected in parallel to the leakage control system. The water sensors are located in the false floor in the server room. In this way, leaks are detected at an early stage. A failure of the computers with data loss is prevented, as the three KHS PLUS quarter turn stop valves cut

off PWC, PWH and PWH-C at the same time. The installation of an alarm horn supports leak detection acoustically. It is also possible to forward a fault signal to the BMS.





**Option 2:
Time-controlled protection**

**Example laundrette with
timer monitoring**

After the laundrette closes, the drinking water lines to the washing machines are automatically closed. Water damage is avoided. Safely and reliably.

The components



KHS Timer,
Figure 686 02 012



Quarter turn stop valve
with spring reset actuator
Fig. 620 01/03



Water sensor,
Figure 620 00 001

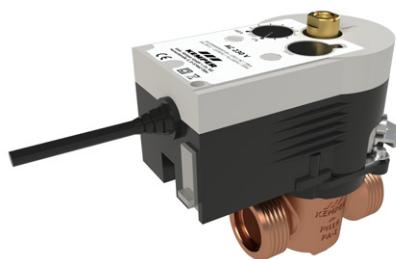

Quarter turn stop valve with
actuator,
Figure 620 00

Benefits at a glance

- // Leakage monitoring and time-controlled flushing of the drinking water system thanks to customised programming
- // Reliable leak detection by means of a water sensor with immediate isolation of the drinking water system
- // Low-noise opening and closing through stop function without water hammers
- // Remote fault message monitoring through connection to building management system (BMS)



Safety group

Benefits at a glance

- // Low space requirements thanks to compact configuration
- // Hygienically beneficial thanks to easy-flow construction
- // Features shutoff valve, controllable RV and additional second shutoff, pressure relief valve and drain funnel in accordance with DIN EN 1717
- // Can be used flexibly in both horizontal and vertical pipes due to modular base flange

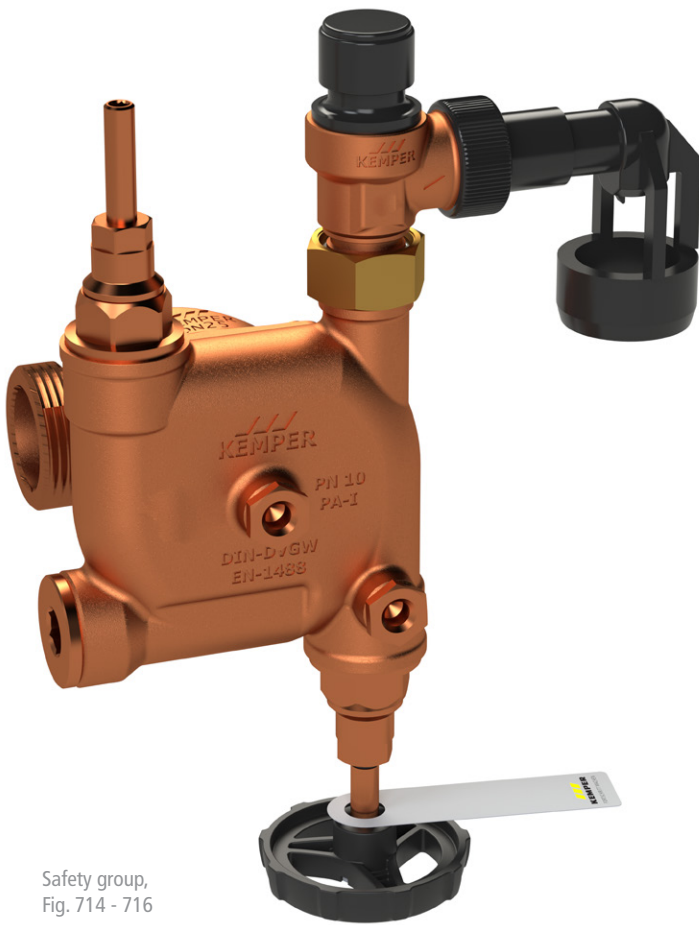

Safety group,
Fig. 714 - 716

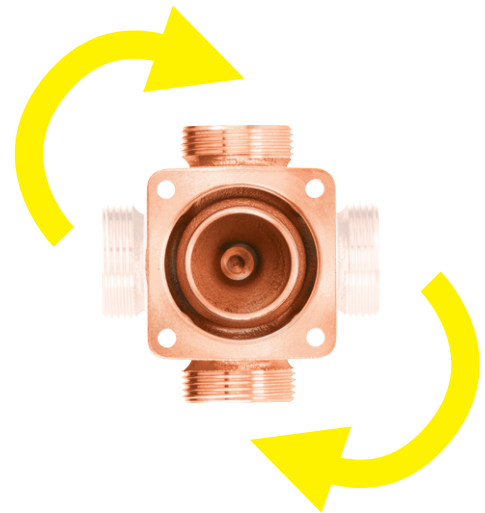

Can be connected both horizontally and vertically!

Practical example: boiler room

All required safety valves and the anti-pollution check valve, shut-off valve, test connection and pressure relief valve (e.g. drinking water tanks) are integrated only in one product. This makes for a space-saving and simultaneously low-cost solution.

PRESSURE REDUCING VALVES AND FILTERS

MULTIFUNCTIONAL AND SPACE-EFFICIENT

Pressure reducing valves compensate for pressure fluctuations and pressure peaks in the public pipe network and ensure steady pressure in the following drinking water installation systems. With a pressure reducing valve, the pressure can be reduced to preserve technical equipment and valves and prevent malfunctions.

Filters can be combined with pressure reducing valves. The compact design makes installing filters and pressure reducing valves cost-effective and space-efficient. Unlike replaceable filters, the filter element of back-flushing filters, which normally has to be cleaned, does not need to be replaced.

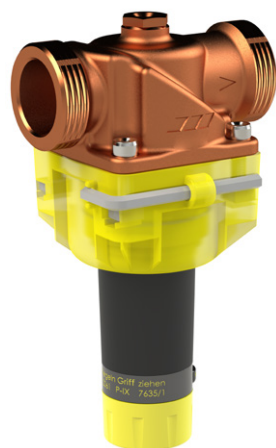

Pressure reducing valve,
Figure 710 0G

Pressure reducing valve

Benefits at a glance

- // Any installation position possible through 360° rotatable cartridge, thus preset pressure can always be read off
- // Corrosion-resistant as wetted parts are made of gunmetal and stainless steel
- // Simple operation of setting values, no tools needed

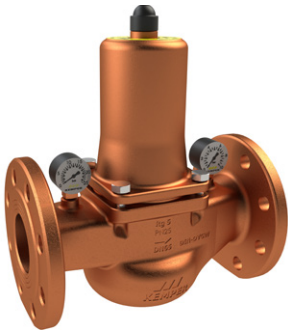

Pressure reducing valve, flanged,
Fig. 711 00

Pressure reducing valves, flanged

Benefits at a glance

- // Corrosion-resistant as wetted parts are made of gunmetal and stainless steel
- // Maintenance-friendly thanks to maintenance when installed
- // Front and back pressure zones controllable thanks to manometer included in the scope of delivery



Filter,
Figure 712 0G

Filter

Benefits at a glance

- // Simple operational state control through differential pressure controlled backwashing and monthly maintenance indicators
- // Hygienically beneficial design thanks to opaque filter cup which prevents microbial contamination
- // Horizontal and vertical installation possible through base flange



Pressure reducing valve filter combination,
Figure 713 0G

Pressure reducing valve-filter combination

Benefits at a glance

- // Simple operational state control through differential pressure controlled backwashing and monthly maintenance indicators
- // Hygienically beneficial design thanks to opaque filter cup which prevents microbial contamination
- // Simple operation of setting values, no tools needed



Automatic backwash
modules for filter F and DMF,
Figure 712 99 004

Automatic backwash modules for filter F and DMF

Benefits at a glance

- // Hygienically safe thanks to automated backwashing
- // Flushing may be triggered by means of remote switch or BMS
- // Remote monitoring of installation and delivery via BMS
- // Simple operation and system monitoring thanks to backwashing intervals that can be set between four minutes and three months in 16 stages.

BALANCING VALVES

DANGER ZONE HOT WATER: PROTECT DOMESTIC WATER INSTALLATIONS FROM LEGIONELLA

To reduce the growth of Legionella bacteria in domestic water installations, maintaining good water temperatures is of particular importance. To maintain temperature above the required minimum temperature of 55°C in hot water circulation installations, hydraulic balancing must be ensured by using balancing valves.

MULTI-FIX-PLUS static balancing valve

MULTI-FIX-PLUS static balancing valves allow fine volume flows to be manually set on the basis of defined valve-setting values.



MULTI-FIX-PLUS static balancing valve, with plugged drain port, FPT
Figure 151 06



MULTI-FIX-PLUS static balancing valve, with plugged drain port, MPT,
Figure 150 6G

Series overview

MULTI FIX-PLUS static balancing valve, with plugged drain port, FPT

Figure no..

151 06

MULTI-FIX-PLUS static balancing valve, with plugged drain port, MPT

150 6G



MULTI-THERM thermostatic balancing valve

The MULTI-THERM combines several functions into a single valve: thermal balancing of the volume flow, shutoff, drainage and temperature monitoring. MULTI-THERM works not only in the operating temperature range of 50–65°C, but also automatically supports thermal disinfection at temperatures > 70°C.



MULTI-THERM thermostatic balancing valve, MPT, Figure 141 0G



NIRO MULTI-THERM thermostatic valve, stainless steel, with plugged drain port, MPT, Figure 041 0G

Series overview

	Figure no.
MULTI-THERM thermostatic balancing valve, incl. dial thermometer and drain valve, MPT	141 0G
MULTI-THERM thermostatic balancing valve, with plugged drain port, FPT	143 00
MULTI-THERM thermostatic balancing valve, with plugged drain port, with permanently integrated MAPRESS press connection	143 22
NIRO MULTI-THERM thermostatic balancing valve, stainless steel, with plugged drain port, MPT	041 0G



ETA-THERM thermostatic balancing valve

As very low volume flows are required to maintain the temperature in a bathroom on account of reduced heat-dissipating surfaces, KEMPER has developed the ETA-THERM specifically for this case. Its k_v value ($k_{v\min} = 0.05$, $k_{v\max} = 0.4$) is specially tailored to meet the needs of the floor area.



ETA-THERM thermostatic balancing valve, 56–65°C, MPT, Figure 130 0G



UP-ETA-THERM flush-mounted thermostatic balancing valve, 56–58°C, FPT, Figure 540 02

Series overview

	Figure no.
ETA-THERM thermostatic balancing valve, 56–58°C, MPT	130 0G
ETA-THERM thermostatic balancing valve, 56–58°C, FPT	131 00
ETA-THERM thermostatic balancing valve, 62–64°C, MPT	134 0G
ETA-THERM thermostatic balancing valve, 62–65°C, FPT	136 00
UP-ETA-THERM flush-mounted thermostatic balancing valve, 56–58°C, FPT	540 02
UP-ETA-THERM flush-mounted thermostatic balancing valve, 56–58°C, with permanently integrated MAPRESS press connection	542 02
UP-ETA-THERM flush-mounted thermostatic balancing valve, 56–58°C, with permanently integrated SANPRESS/PROFIPRESS press connection	544 02
UP-ETA-THERM flush-mounted thermostatic balancing valve, 62–64 °C, FPT	540 62

Schematic diagram of a circulation system with circulation in the riser

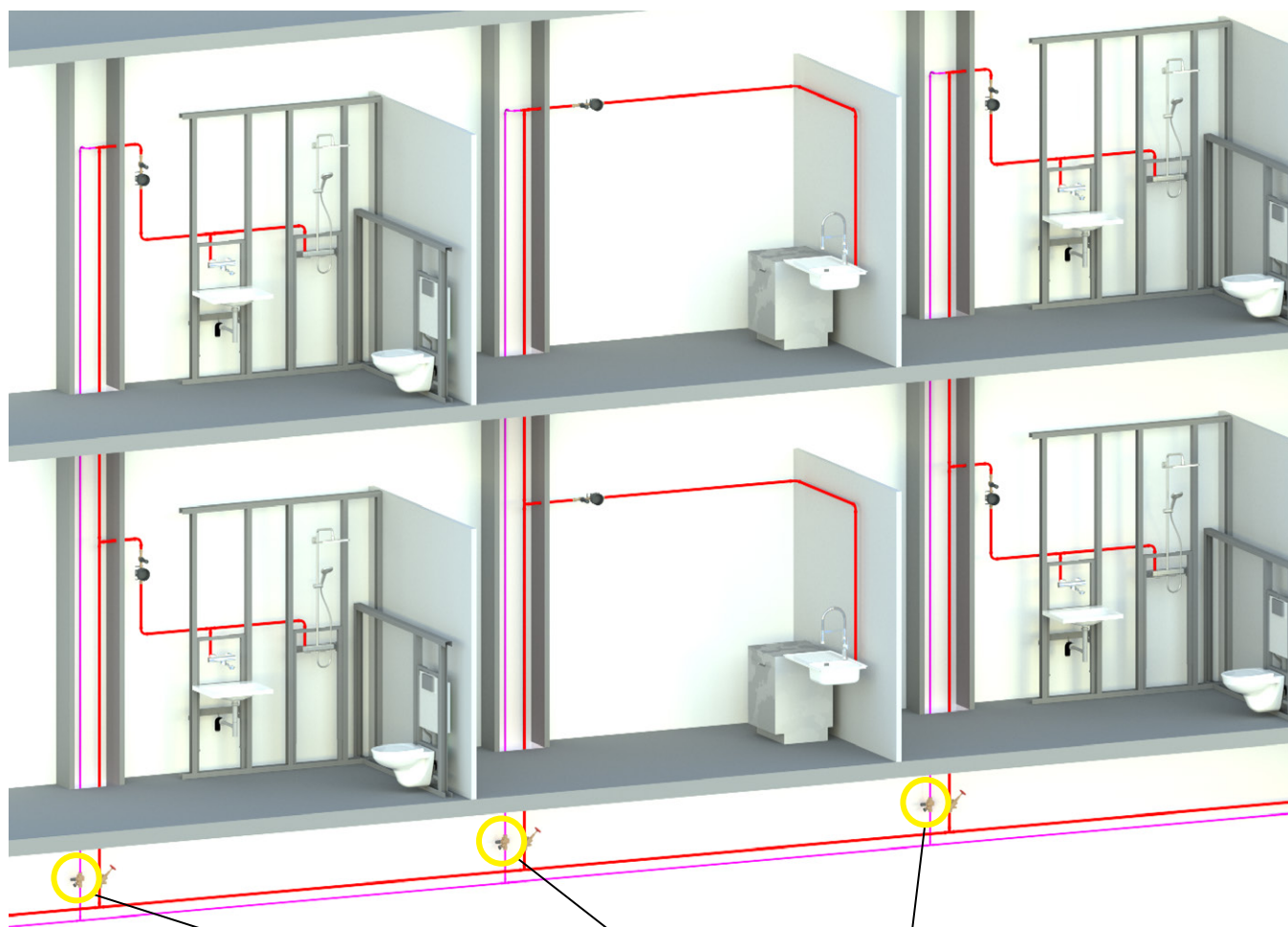

Apartment water meter and circulation combination

With apartment water meters, it is possible to install the circulation system in the riser. Hydraulic balancing between the risers is guaranteed by thermostatically controlled valves. It is important to ensure that the non-circulating volume does not exceed three litres in the floors.



MULTI-THERM thermostatic balancing valve, Figure 141 0G

Schematic diagram of a circulation system with circulation as far as the tapping points with two-stage adjustment (circulation system in the floor area)

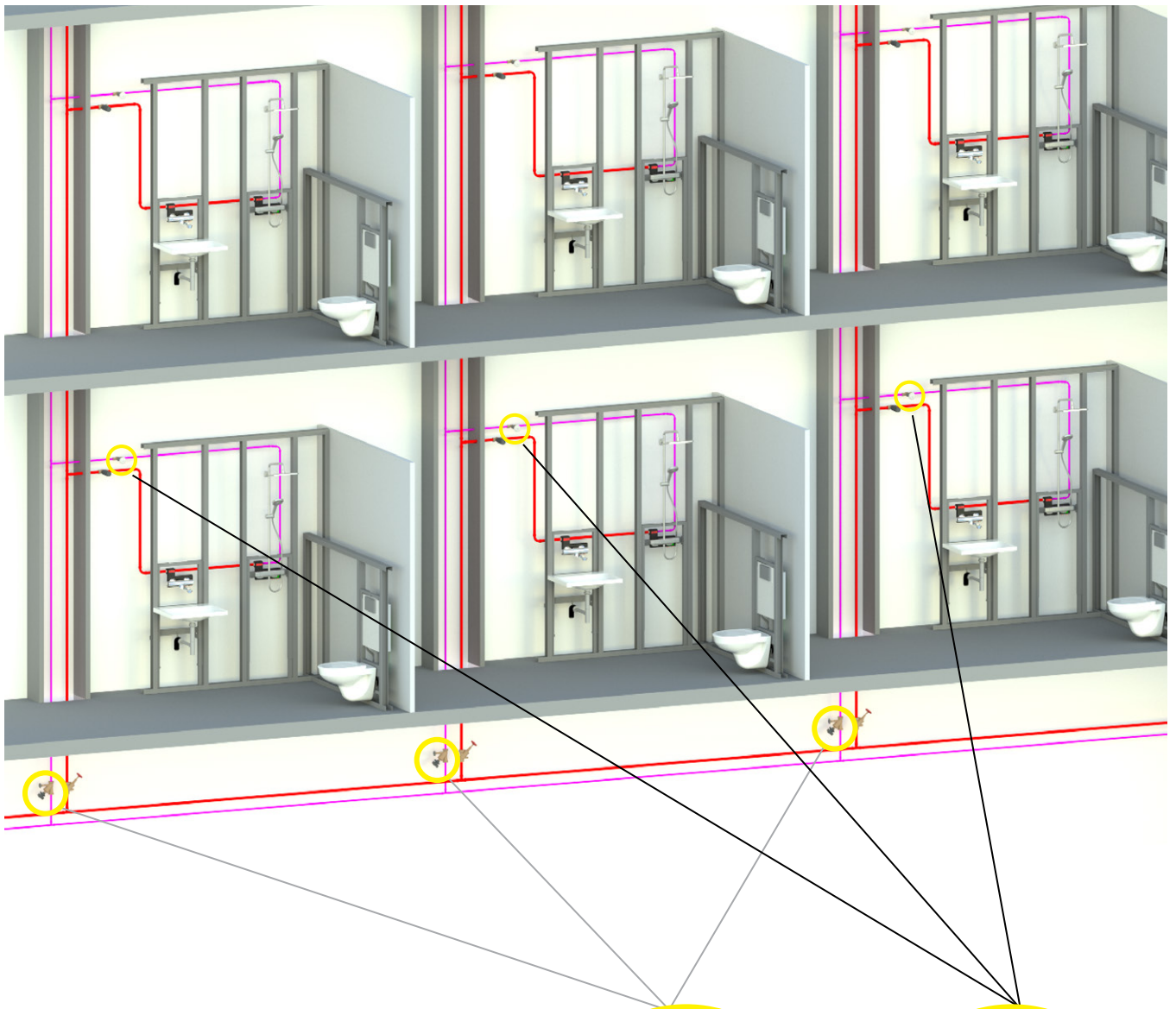

Combination of static and thermal

With multi-stage adjustment, it is important to note that there must always only be one thermostatically controlled valve in the circulation circuit. In order to maintain valve authority, only the first valve in the circulation circuit may be a thermostatic valve.



MULTI-FIX-PLUS static balancing valve, Figure 150 6G



ETA-THERM thermostatic balancing valve, Figure 130 or Figure 540 (UP)

MEASURING PRODUCTS

ANALYSE AND OPTIMISE OPERATING STATES

Unknown operating parameters?

Unknown operating parameters such as temperature, pressure, volume flow and flow velocity in a drinking water installation can lead to hygiene problems. With the KEMPER measuring products portfolio, all unknown system information can be conveniently measured, adjusted and documented!

KEMPER measuring products support the creation of:

- // Temperature draw-off profiles
- // Risk analyses and hydraulic balancing in existing properties
- // Operating parameters in existing buildings
- // Demand-driven calculations of drinking water systems and hot-water storage



CONTROL-PLUS

For measuring/reading/
saving



KHS MASTER 2.1 Mini Control System
Figure 686 02 008



CONTROL-PLUS hand-held measuring device with digital display and storage option for logging,
Figure 138 00 005



External building management system

Connections for CONTROL-PLUS components



Pressure sensor
Figure 138 00 006
To collect the system pressure in the drinking water system. Metering range 0–1 MPa.



CONTROL-PLUS plug-in temperature sensor
Figure 138 00 004
To collect system temperatures in the drinking water system. Temperature sensor 0–100°C, cable length 2.0 m



Sensor measuring module
Figure 138 00 011
For quick and easy readout of measurement points through the CONTROL-PLUS hand-held measuring device.



Hand-held temperature sensor,
Figure 138 00 003
To measure water temperatures, in particular drinking water temperatures in the area of the outlet of the tapping points on site. Fast reacting sensor for detection of temperature fluctuations; temperature measurement range 0–150°C; 150 mm long measuring probe made of stainless steel; cable length 1.0 m.



CONTROL-PLUS flow and temperature measuring valve,
Figure 138 4G/BMS version Figure 138 6G
To precisely determine and adjust volume flows in drinking water systems. Sensor housing with low pressure loss; min. flow velocity 0.2 m/s; max. flow velocity 2.5 m/s; temperature measurement range 0–100°C.

Benefits at a glance

- // Perfectly suited to existing properties
- // User-friendly design
- // USB interface and integrated web server for measurement data readout
- // CONTROL-PLUS hand-held measuring device: storage of up to 12,000 data points
- // Usable with or without a building management system

Measuring points can be placed in the drinking water installation

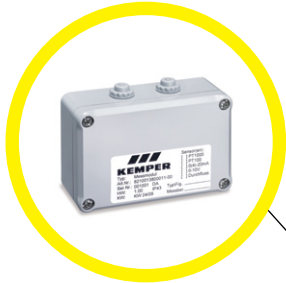

If the valve is located in a false ceiling or another space, the measuring point can be shifted.



To be able to react to pressure fluctuations of the supplier, the pressure should be measured upstream of the pressure reducing valve.



The temperatures across the entire cold water pipework must not exceed 25°C. Increased temperatures must be taken into account, especially in the summer months. In this case, to be able to react to the change in circumstances, a temperature measurement can be taken.

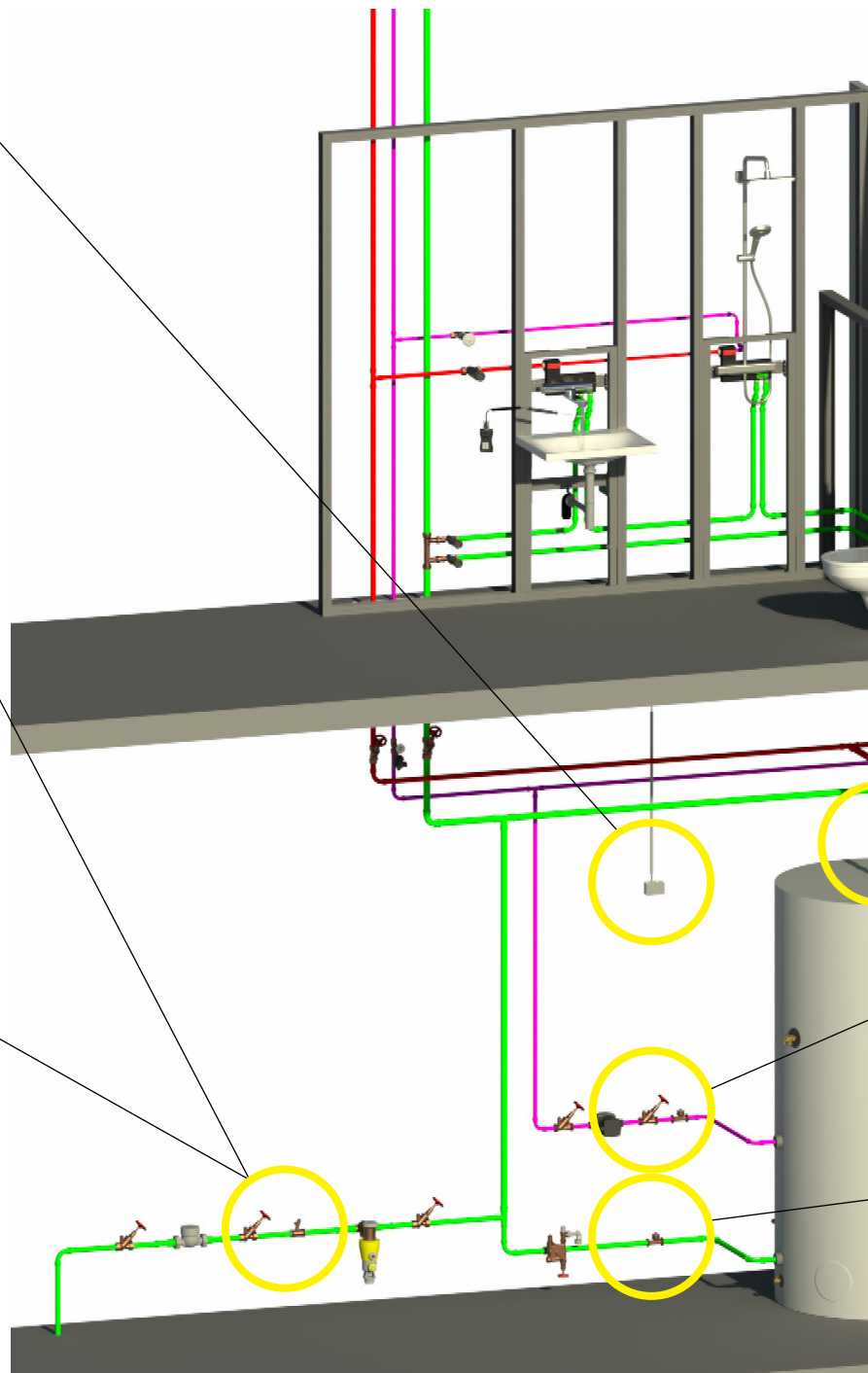

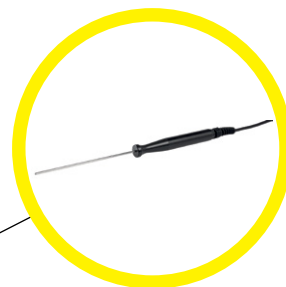
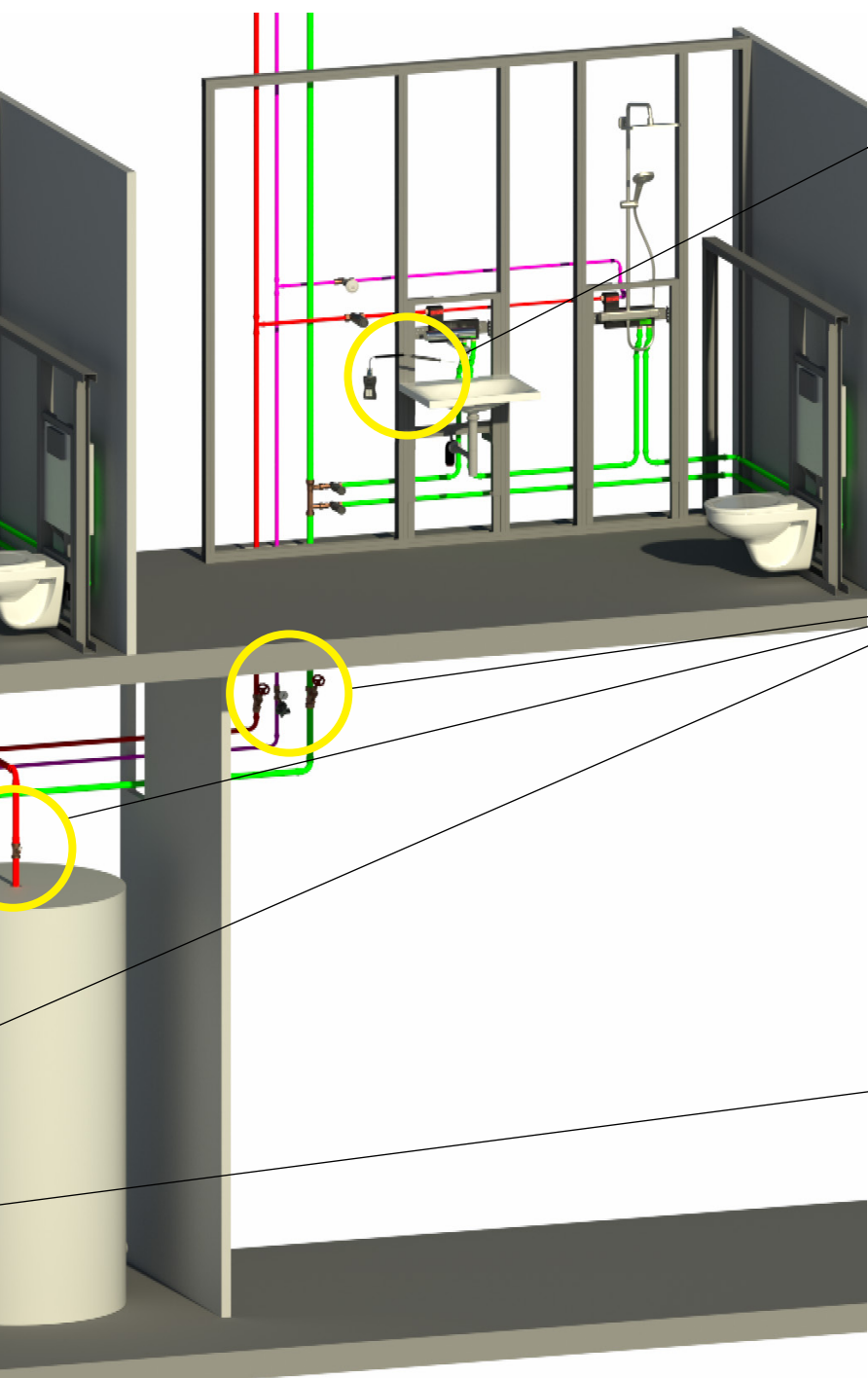

To create a temperature draw-off profile, a temperature measurement can be taken.

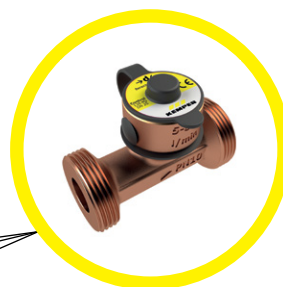

To adjust and/or check the hydraulic balance, temperature and flow can be measured.



Temperature and flow can be measured in order to draw a precise conclusion about the hot water consumption and consumption peaks.

FLUSH- MOUNTED- SOLUTIONS

UP-PLUS VALVES AND SHUTOFF WATER METER PRODUCTS

The wide range of UP-PLUS and shutoff water meter products gives designers and plumbers free rein when it comes to choosing function, installation and connection technology. This versatility not only offers a whole package of important benefits, but also pays off by saving on costs in every installation as it provides flexibility for all walls with future-oriented technology.

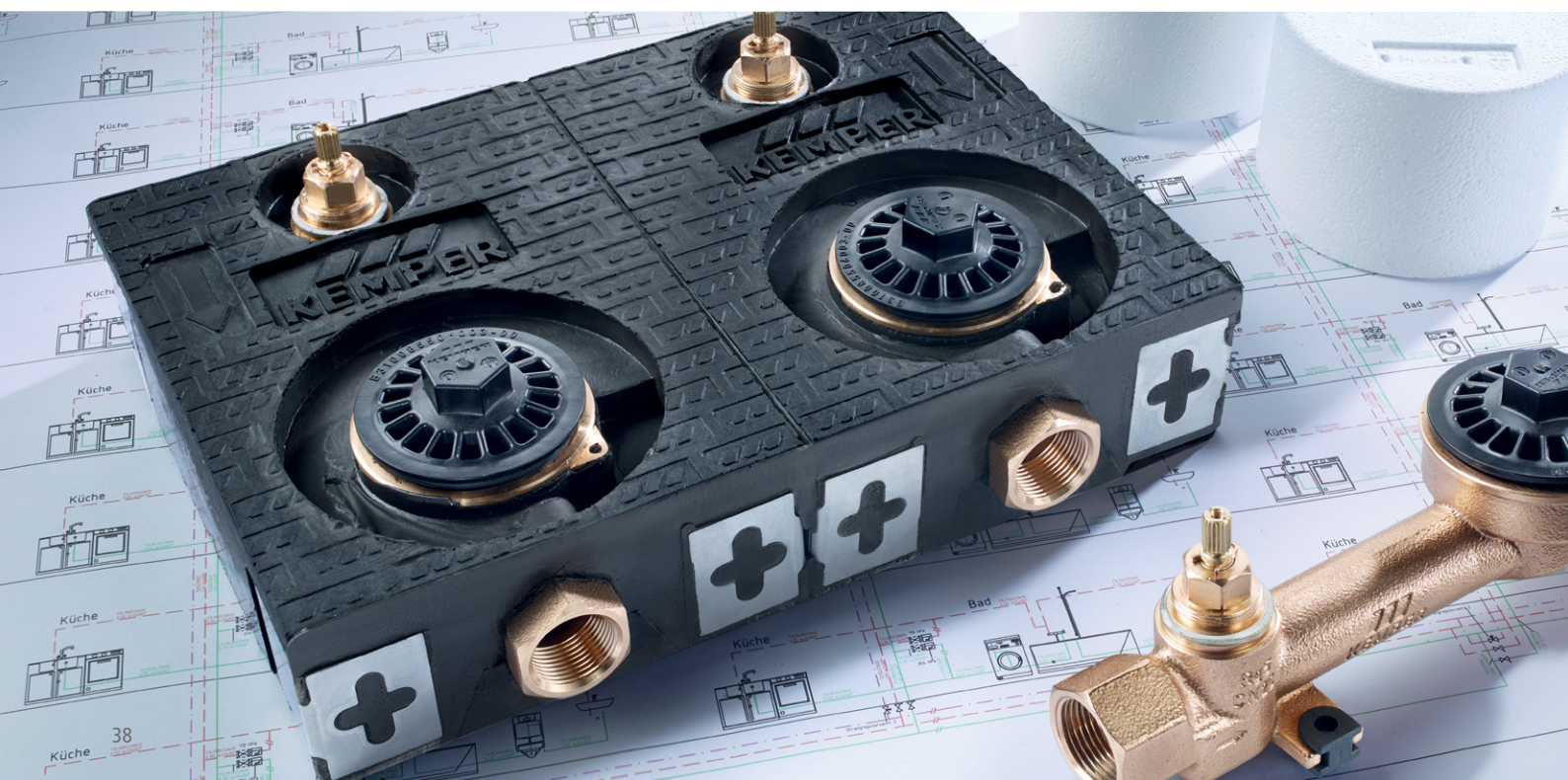

UP-Plus valve – flexible in function and connection technology

KEMPER UP-PLUS valves are characterised by design details on the valve bonnet, plastic shaft and valve housing and can be integrated in almost all drinking water installations thanks to the different valve and connection types.

Connection system:

- // Universal female threaded connection
- // Press connections for SANPRESS/PROFIPRESS and MAPRESS systems

Installation type:

- // For flush-mounted installations of any kind
- // Firm mount even in pre-wall installations thanks to optional mounting set, Figure 597 00



Quarter turn stop valve with sleeve connection, Figure 585 00



FM-PLUS flush-mounted valve with fixed press connection with SC Contur SANPRESS and PROFIPRESS systems, Figure 560 06



UP-PLUS flush-mounted valve with permanently integrated MAPRESS press connection and set for final installation Figure 560 22



UP-PLUS flush-mounted valves, FPT Figure 560 01

Benefits at a glance

- // Prevents bacterial growth by being free from dead spots
- // Flexible use thanks to choice between grip unit and operating cover
- // Corrosion-resistant as wetted metal parts are made of gunmetal



Stop valve water meter combinations

Fix, orient, connect: easy, precise, clean.

With KEMPER combinations, mounting blocks and the water meter housings, mounting can be easy and highly economical. Especially at hard-to-reach spots as well. Finish the entire mounting process within minutes and enjoy great results. Very handy for your customers. KEMPER's renown level of quality ensures reliability, as stop valves and water meter housings are made entirely of gunmetal.

In old and new buildings, water meters must be installed as quickly and inconspicuously as possible for demand-based billing for hot and cold water. For the maintenance of the water meters, shutoffs should be provided on the floor. The range of water meter shutoffs made of reliable gunmetal with a defined inside micrometre between the isolating unit and the water meter is the perfect choice for this.

Benefits at a glance

- // Suitable for every installation situation: brickwork, partition and pre-wall installation
- // Perfectly aligned installation due to solid connection of water meters and stop valves
- // Corrosion-resistant as wetted metal parts are made of gunmetal
- // Flush-mounted valve free from dead spots and with maintenance-free spindle gasket



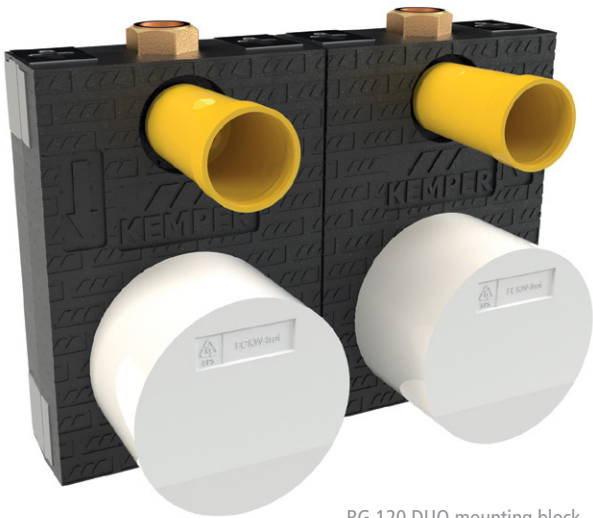

RG 120 DUO mounting block,
Figure 854

RG120 stop valve water meter series

Benefits at a glance

- // No soldered joints or connections on shutoff body as water meter section is cast as a single piece.
- // Flexible use thanks to mounting lugs and separable water meter block
- // Optimum heat insulation thanks to pressure and tension-resistant PU rigid foam, building material class B2
- // Available with manufacturer-specific or universal water meter housings

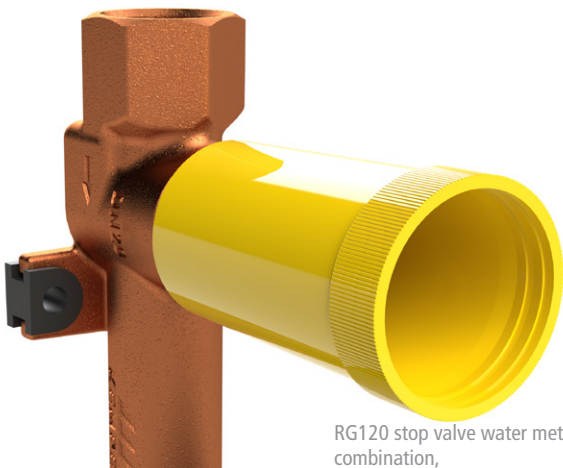

RG120 stop valve water meter
combination,
Figure 855 47

Benefits at a glance

- // Easy installation thanks to integrated fastening bases
- // No soldered joints or connections on shutoff body as water meter section is cast as a single piece
- // Available with manufacturer-specific or universal water meter housing
- // Measurement capsule can be seamlessly replaced thanks to stop valve in water meter section



DUO stop valve water meter box,
DUO,
Figure 870 07

DUO STOP VALVE WATER METER BOX

Benefits at a glance

- // Anti-twist, sound-insulated stop valve water meter combination cast as a single part
- // Corrosion-resistant as wetted metal parts are made of gunmetal
- // Suitable for any pre-wall system thanks to a wide range of fastening options and accessories
- // Can be combined with commercially available access and cover systems, suitable for radio readouts compliance of building material class B1

FROST-PROOF OUTDOOR TAPS

GET A RELIABLE
WATER SUPPLY FOR OUTSIDE.

Reliable with long service life

It's something every garden or outside area of a building should have – outside taps to ensure the supply of drinking water continues all year round. With its FROSTI® frost-proof outdoor tap, KEMPER provides a robust, long-lasting outside tap that's specially designed to be particularly frost-resistant and hygienically sound. FROSTI® is equipped with an anti-vacuum valve and automatically drains itself after every shut-off procedure. Therefore, no residual water is left behind in the frost-prone area, avoiding water damage caused by the tap freezing. This complete drain-

age also prevents bacteria growth due to stagnant water, maintaining drinking water hygiene.

The challenge

Is it possible to equip such a sophisticated product with new, meaningful features? KEMPER sought to answer this question with the help of its experienced technicians, as it's a case of accounting for unfavourable installation situations, discerning end users, improper use and undesired third-party access



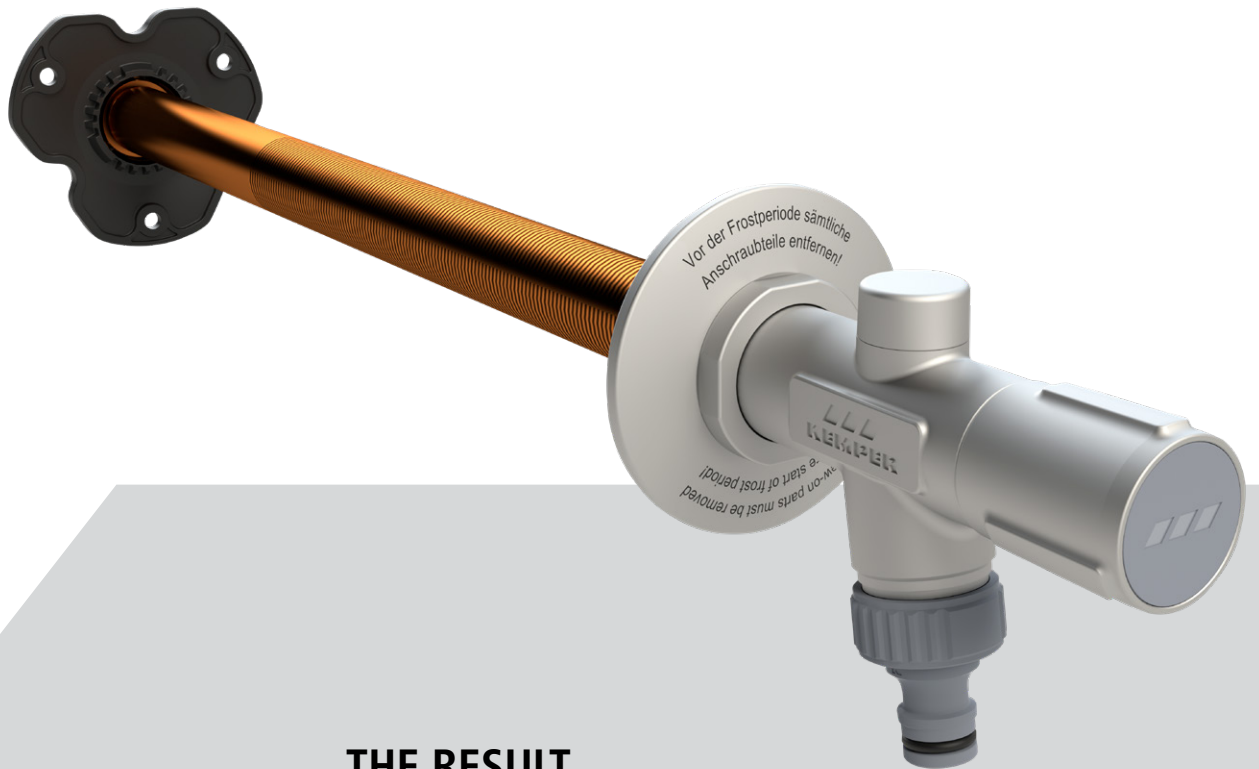

THE RESULT

From the knowledge it has gained, Kemper has developed numerous features in response to problems that arise. This is the new FROSTI® – the advancement that's taking already sophisticated technology to a new level:

New functions

New installation advantages

Proven gunmetal



Product versions There's a tap for every use case



FROSTI® and FROSTI®-XL for installation in the shell construction phase

The kit allows the installation of the tap as early as the shell construction phase. The discharge body is mounted after the outer wall has been completed. Installation depths of up to 415 mm (XL version up to 530 mm) can only be achieved with such an end-to-end length. Additionally, the extension allows the thermal insulation system to be bypassed.

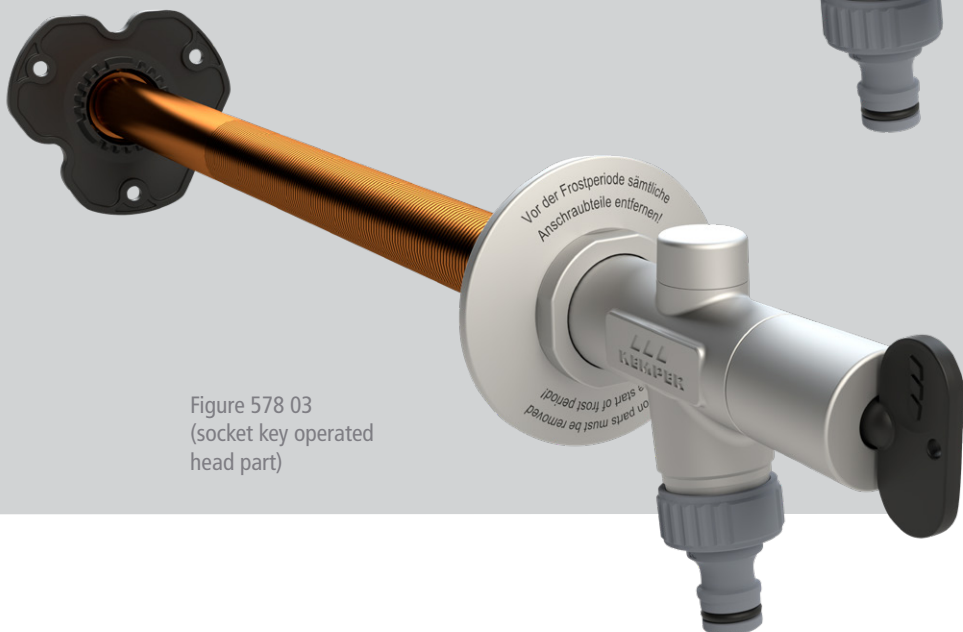
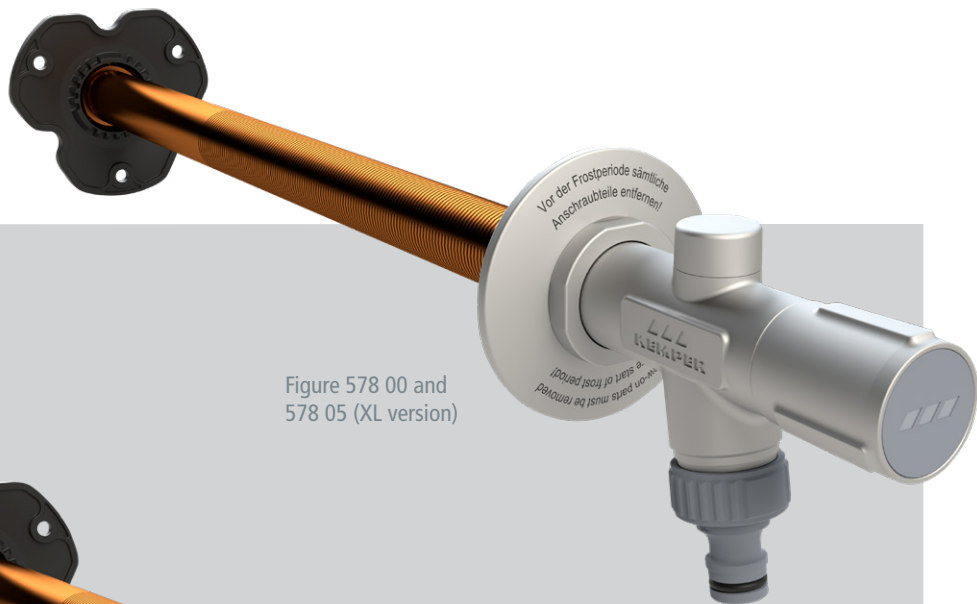

FROSTI® pre-assembled design for installation in finished façades

The tap comes pre-assembled with a total outer diameter of just 27 mm and a movable rosette, allowing for quick and simple installation in already constructed outer walls

- // for wall thicknesses from 150 mm, can be extended to any length during installation
- // With universal R 1/2" connector, suitable for every installation system



Figure 579 02

INFO

Functions

- // With just two turns FROSTI® can be fully opened, reaching the maximum discharge rate.
- // The tap automatically drains itself fully after every shut-off procedure, preventing the valve from freezing and avoiding water damage.
- // The absence of stagnant residual water means no contamination will occur.

Overview of part numbers

Part no.	Product description	Nominal width
5780001500 5780002000	FROSTI® frost-proof outdoor tap with operating handle, construction set version	DN 15 DN 20
5780301500 5780302000	FROSTI® frost-proof outdoor tap, with socket key, construction set version	DN 15 DN 20
5780501500 5780502000	FROSTI® XL frost-proof outdoor tap, with operating handle, XL construction set version	DN 15 DN 20
5790201500	FROSTI® frost-proof outdoor tap, pre-assembled design	DN 15

The new advantages in function and assembly

// New handle with over-twist protection and an elegant, uniform design

KEMPER has both a handle and a lockable handle, equipped with an outstanding functioning element. The integrated over-twist protection prevents damage to the tap caused by it being closed with excessive force.

Additionally, the two handle versions and the socket key operated head part are characterised by a uniform, consistent design. The valve integrates into the façade in an aesthetically pleasing manner.



When closing the tap, the handle is rotated until the closing point is reached.

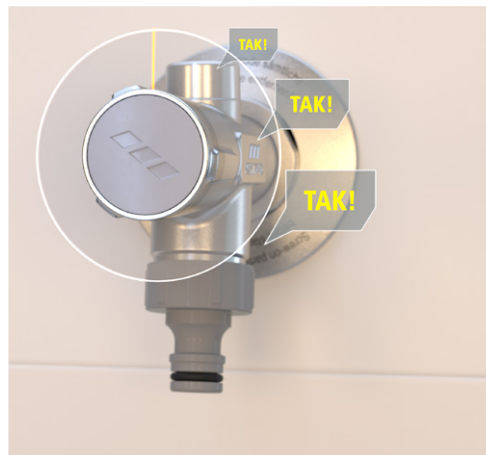

The anti-twist protection prevents the handle mechanism from over-rotating past the closing point. This protects the components from being damaged by excessive closing force.

// Theft protection

The breather cap and socket key operated head part are no longer screwed in but instead latch into the discharge body, creating a theft-proof connection.

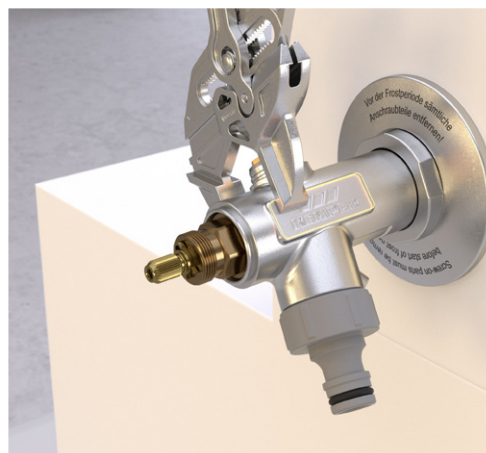



// **Two-piece collar**

The two-piece collar adapts to the angle of the inclined bore so that it's always flush with the wall, ensuring a neat fit. Thanks to this, the tap benefits from an increased holding effect. This prevents the façade from being damaged when screwing on the discharge body and stops the external wall insulation from being compressed.

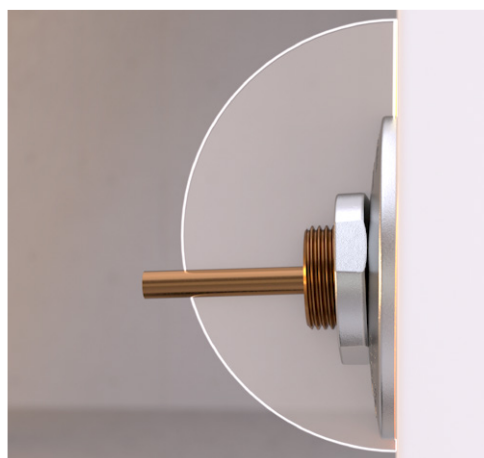
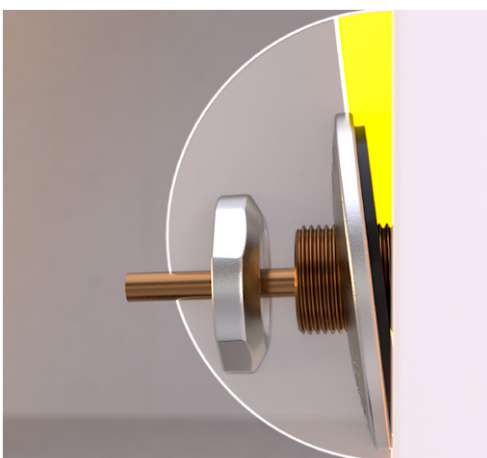

// **New mounting surfaces**

The newly designed mounting surfaces on the discharge body provide optimal support for the installing technician and prevent surface damage during installation.

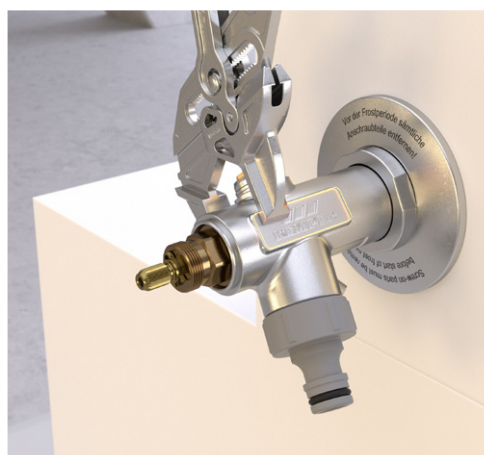

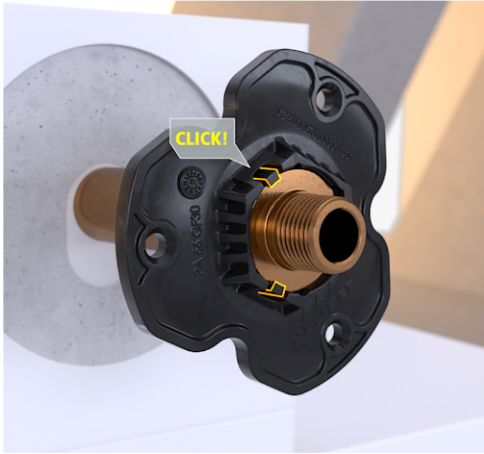

// Optimised anti-twist protection

The new anti-twist protection latches into the valve seat. The connection to the drinking water line is protected from radial and axial forces, even during shell construction assembly. Thanks to an integrated bore guide, holes no longer need to be marked.



// Up to 45 l/min discharge

End users benefit from the unmatched, new discharge rate of 45 l/min at 1 bar in DN 20 (40 l/min in DN 15).

// Tried-and-tested gunmetal

Clean, reliable, hard-wearing – corrosion-resistant gunmetal is a material which has proven itself in providing years of worry-free functional reliability in domestic water installations.

// Spare parts availability

Spare parts are available for all generations of the frost-proof FROSTI®, even if they're well past the minimum statutory period.



Also learn about the advantages in the new FROSTI® functions video!



YouTube



Accessories for optimal installation



Lockable handle

Protection against impermissible removal of water by unauthorised third parties – and much more! The lockable cap (part no. 5780000300) is compatible with all FROSTI®s since 2009 and is an indispensable accessory for the FROSTI® NEW thanks to a range of new features!

The elegant, slim design fits in perfectly with the design language of the handles and ensures comfort when gripping. The integrated over-twist protection prevents damage to the valve caused by it being closed with excessive force. It can now be efficiently installed and removed in under a minute without the need for a separate removal key. Optional master key cylinder available when ordering.



FROSTI® extension

Thanks to the FROSTI® extension (part no. 5780000200), the frost-proof outdoor valve (Figure 578 00, 578 03 and 578 05) can be adapted with infinite variability between 30 to 250 mm to modified installation depths, e.g. over the course of cleaning a building with new external insulation.

Compatibility from old to new

Upgrading old models (manufactured from 2009 onwards) with the new over-twist protection is straightforward and efficient, as the new handle and the lockable handle can be retrofitted at any point.

For models manufactured between 2006 and 2008, a complete retrofit set is available with a discharge body, collar and a new handle.

FROSTI® fixing set

The FROSTI® fixing set (part no. 5780000500) ensures the valve is securely in place in the brickwork even when the mechanical load on the façade is higher, e.g. double-sheet outer wall. This prevents signs of wear on the plaster or façade.

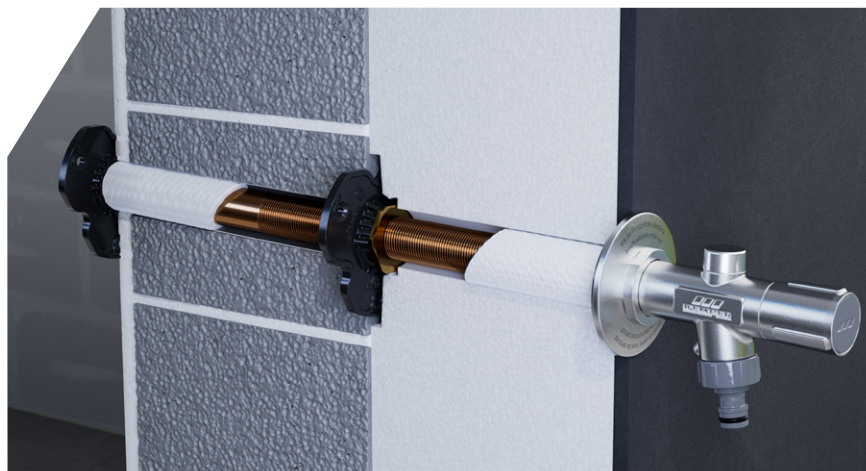

TRESOR CABINETS

COMPACT SUPPLY STATIONS
FOR WATER AND ELECTRICITY

Technically sophisticated and elegant in design

KEMPER TRESOR provides a convenient water and electricity supply simultaneously at a central location. The compact supply station for outside can be seamlessly integrated in brickwork or concrete walls and blends harmoniously into the architecture.





TRESOR and MINI-TRESOR



MINI-TRESOR built-in wall cabinet, Figure 211



MINI-TRESOR surface-mounted wall cabinet, Figure 212



TRESOR built-in wall cabinet Figure 210



TRESOR surface-mounted wall cabinet, Figure 213 (alternatively Figure 214 specially for a chlorine-based environment)

Supply guarantee even at problematic points

It doesn't matter whether it's for private, public or business use, KEMPER TRESOR is always the right choice! TRESOR comes into its element anywhere where electricity and water supplies need to be protected against vandalism. Electricity and water theft are prevented while individual use remains protected. In order to ensure public safety, TRESOR also helps prevent electric shock in public and business areas, e.g. sports and leisure facilities. It can also be integrated seamlessly in locking systems, as the security key lock can be retrofitted as needed. And, depending on structural conditions, TRESOR is available as a built-in or surface-mounted wall cabinet.

The supply station provides various connection options, e.g. water and electricity connections for 230 V/400 V, which can be expanded on site to include, for example, gas, telephone, antenna or wastewater connections for private and commercial applications.

Thanks to its compact and robust construction, TRESOR can be used for a wide variety of applications:

- // In single-family dwellings
- // In swimming and open-air pools
- // On camping sites
- // At clubhouses
- // At shooting ranges
- // In schools and nurseries
- // In hospitals
- // In residential buildings of any kind
- // In leisure facilities

Benefits at a glance

- // Attractive design thanks to high-quality stainless steel surface (no. 1.4404)
- // Protection from frost damage thanks to integrated FROSTI® (frost-proof outdoor valve)
- // Integration in existing locking systems thanks to convertible security key lock
- // Increased safety thanks to optional residual current protection device



SAMPLING VALVES

DRINKING WATER QUALITY MONITORING – THE RIGHT SOLUTION FOR EVERY INSTALLATION SITUATION

Existing standards and regulations must be fulfilled – the basic prerequisite for a sampling valve! However, there are also other requirements which plumbers, samplers and operating companies have to meet. The availability of **variants for all areas of application** and a **cost-saving, variable**

installation are just as important as the option **to use alternative disinfection methods** and the ability to take samples easily. In addition, **dripping sampling points** – even after repeated flaming – or **unauthorised removal of water** (water theft) are not acceptable.





Sampling valve,
Figure 187 00,
or stainless steel,
Fig. 087

Sampling valve with
anti-pollution check valve
for use at angled stop valve
Figure 188 01

Ready for anything! Comprehensive requirements for sampling valves

Sampling valve variants

For easy retrofitting in existing shutoff and balancing valves, KEMPER sampling valves come in the G 1/4 and G 3/8 designs.

Cost-saving, variable installation

The ability to rotate the valve by 360° in two planes always permits vertical sampling with a pencil-thick flow of water.

Alternative disinfection methods

In addition to the option of flaming, the outlet pipe for chemical disinfection can simply be removed by means of a clamping ring connection.

No more dripping sampling points

The disk gasket in the shutoff consists of temperature-resistant PTFE in order to guarantee a permanent seal here against the system pressure.

No more unauthorised removal of water

In order to prevent "water theft", KEMPER sampling valves for sampling from the branch can only be operated using the triangular key provided (gunmetal version only).

For the specifications of the relevant standards, please also see Article 14b of the Drinking Water Directive (TrinkwV). Inspection obligations with regards to Legionella spec.!

Drinking water quality monitoring at different sampling points

The sampling points shown here are a recommendation by Gebr. Kemper GmbH + Co. KG. In general, however, the following applies: The Public Health Department decides when, where and how samples are taken (Article 20, Order by the Public Health Department).

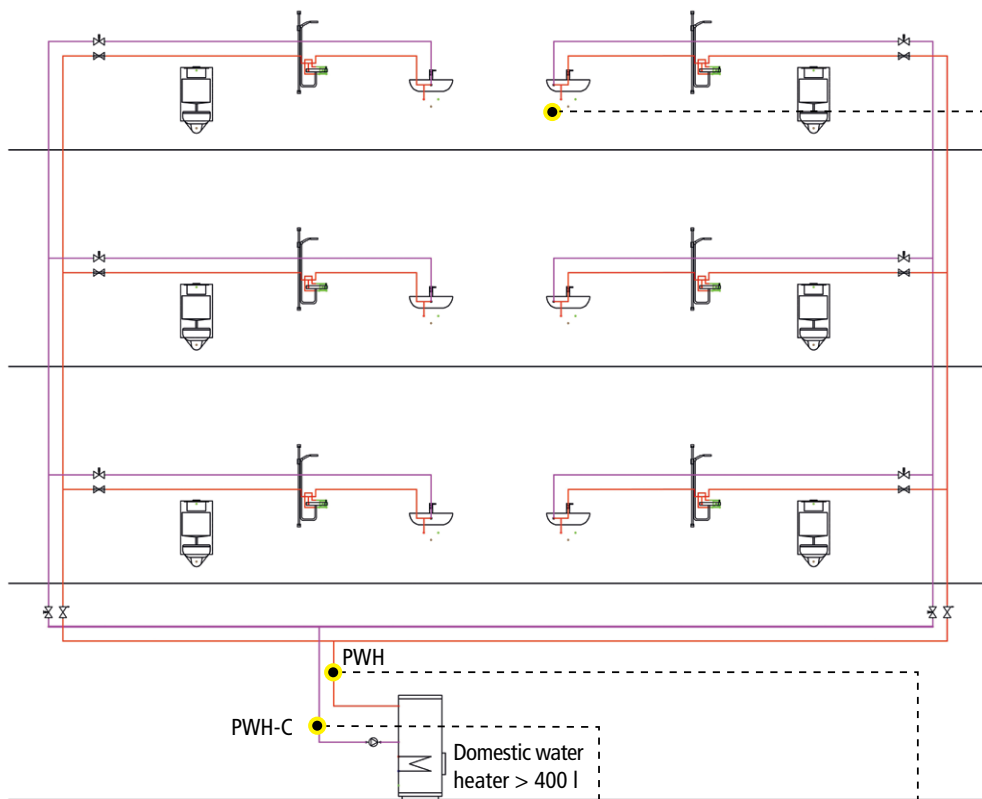

Sampling valve for lines and distribution pipes

Benefits at a glance

- // Suitable for every installation situation thanks to dual 360° alignment
- // Thermal and chemical disinfection thanks to stainless steel drain
- // DVGW-approved



Sampling valve, Figure 187 00



MULTI-THERM automatic circulation balancing valve, Figure 141 0G

WESER free flow stop valve Figure 173 2G



Sampling valve for angled stop valve

Benefits at a glance

- // Protects against any overflow impacts thanks to integrated anti-pollution check valve (Figure 188 01)
- // No interruption of operation because mounted at outlet of angled stop valve
- // Thermal and chemical disinfection thanks to stainless steel drain



Sampling valve for angled stop valve with anti-pollution check valve Figure 188 01



Sampling at the PWH angled stop valve. In the event of a technical defect in the valve, it is possible that the PWC could overflow under a washbasin. Return flow or overflowing of PWC to PWH.

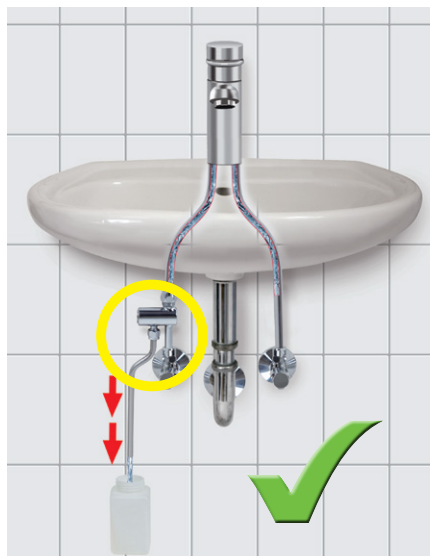

Sampling using a KEMPER sampling valve with integrated anti-pollution check valve under a washbasin. Return flow or overflowing of PWC to PWH is ruled out.

INSULATION SHELLS

SAVE ENERGY IN A SUSTAINABLE WAY IN ACCORDANCE WITH THE REQUIREMENTS OF THE ENEC

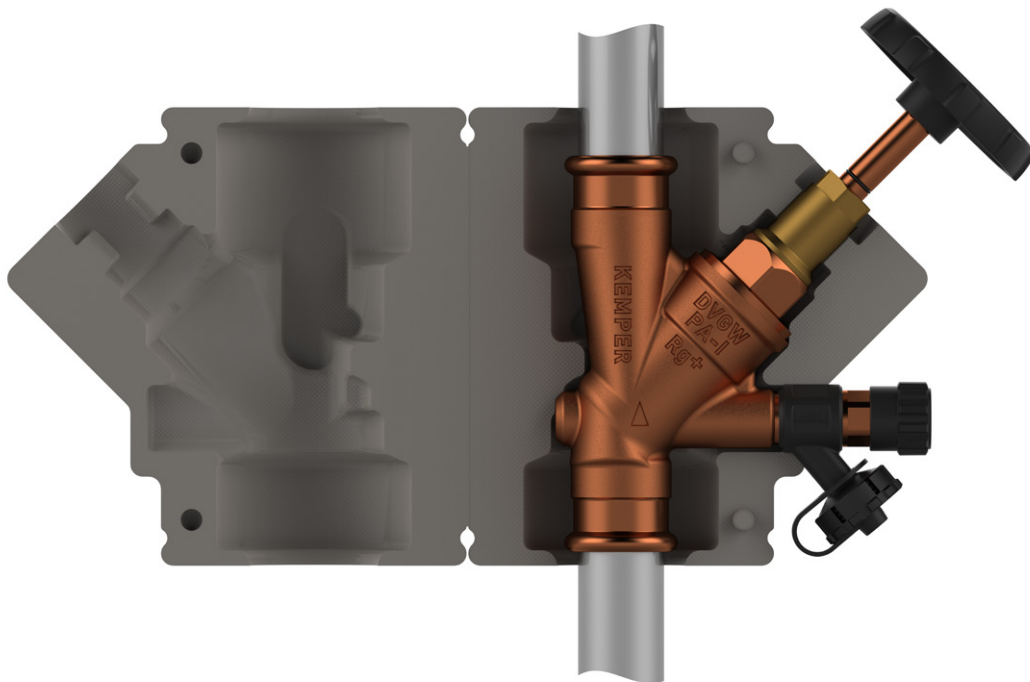

The German Energy Savings Regulations (EnEV 2016) demand that pipelines and valves be insulated

The German Energy Savings Regulations (EnEV 2016) are intended to reduce human-induced global warming and achieve the sustainable use of primary energy resources. The EnEV 2016 places demands on systems for heating, indoor air and hot water provision.

- // Article 4 (5), (6) specifies that heat distribution pipes and hot water pipes installed for the first time, as well as their valves, must be insulated (Appendix 5)
- // Article 10 (2) of the EnEV sets out a retrofit deadline for heat distribution pipes and hot water pipes, including their valves.

For cold water pipes, insulation measures also have to be taken into account to combat condensation, frost and heat from outside.

- // DIN 1988-200, 14.2 Additional requirements for insulation and casings

Fast, economical, reliable

Insulation ensures KEMPER valves are installed quickly and inexpensively and helps to prevent:

- // Energy/heat loss in accordance with EnEV 2016
- // Condensation formation in accordance with DIN 1988-200
- // Bacterial growth in PWC/PWH systems in accordance with VDI/DVGW 6023



Insulation shells



Universal insulation shell for all KEMPER free-flow valves, Figure 471 10



Special insulation shell for MULTI-THERM automatic circulation balancing valve, Figure 471 11



Special insulation shell for MULTI-FIX PLUS static circulation balancing valve, Figure 471 26



Special insulation shell for KEMPER stop valve water meter combinations, Figure 471 16



Special insulation shell for KEMPER KHS quarter turn stop valves and KEMPER flow and temperature sensors, Figure 471 19



Special insulation shell for flush-mounted valves UP-PLUS and ETA-THERM automatic circulation balancing valve, Figure 471 14

Benefits at a glance

- // With CE labelling
- // Made of PE material, suitably shaped for KEMPER valves
- // Building material class B1 in accordance with DIN 4102 T1
- // High temperature-resistance
- // Low thermal conductivity
- // No condensation formation
- // Quick and easy installation
- // Impermeable if bonded with standard adhesives
- // Reliable closing thanks to the mounting clips included

Fixed or removable: everything is possible

- Insulation shells can be
- // reliably closed and opened again thanks to the mounting clips,
 - or
 - // permanently bonded to prevent condensation, using standard adhesives.



HYGIENE SYSTEM KHS

INTELLIGENT SYSTEM SOLUTION
FOR MAINTAINING
DRINKING WATER HYGIENE



The challenge of drinking water hygiene

Like other foodstuffs, drinking water has a limited shelf life. If it sits in the feed pipes for too long it can spoil. If water sits for longer periods of time due to lack of use of an installation layout, it will stagnate.

When stagnation occurs, drinking water absorbs substances from the installation materials as well as temperature from the environment. Both can lead to a change in drinking water quality that is harmful to health. An increase in temperature to over 25°C is particularly risky, as microorganisms such as *Legionella* multiply exponentially in lukewarm temperature ranges.

The requirements for adhering to drinking water hygiene in Germany are strictly regulated by laws, standards and guidelines. For example, VDI 6023-1 requires that the entire water content of the drinking water installation be replaced after 72 h to prevent the concentration of microorganisms in drinking water. A frequent flow of cold water also supports temperature maintenance to a hygienically safe level. A temperature of just <20°C is regarded as safe for cold water, for example, in the DVGW water information 90, but also in many international standards and recommendations.

The German Drinking Water Directive (TrinkwV) therefore imposes an obligation on operators of public buildings in particular to ensure hygienically perfect drinking water throughout the entire installation at all times.

Compliance with the intended use

Experts use the term “intended use” to refer to a hygienic operating mode of the drinking water installation. In addition to frequent maintenance, repair and cleaning work, it particularly entails compliance with the originally intended frequency of use.

The responsibility to comply with the intended use lies with the operator. However, unlike maintenance, repair and cleaning work, usage can only be controlled to a certain extent, yet still must be maintained over the entire life cycle of the building as intended. If this cannot be achieved by the operator alone, suitable – and ideally automated – flushing measures must be provided. This should be economical and environmentally friendly so that drinking water as a resource is not impacted.

Measures for ensuring drinking water hygiene

1.

Preventative design

The basis for achieving a hygienically flawless drinking water installation is preventative design in consideration of the following factors.

Reducing the nutrient supply

The construction materials must be selected such that the nutrients that migrate to the medium are reduced as much as technically possible. This also indirectly serves to prevent microbial growth both on the surface of the material and in the drinking water. All materials must be tested for their suitability for drinking water usage. This “microbial suitability” is a basic requirement of Article 17 of the TrinkwV and is applied by the German Environment Agency as an important criterion for creating material positive lists.

Turbulent flow

The pipe must be dimensioned in such a way that, during intended use, flow velocities occur several times a day which cause appreciable shear forces on the pipe walls, preventing biofilm – a breeding ground for microorganisms – from adhering.

Preventing stagnation

The design of a drinking water installation must, during operation, result in a high water exchange in all parts of the building, particularly in the floor and individual supply lines. Choosing the right type of installation is crucial in this case.

Temperature maintenance

Temperatures which promote the reproduction of microorganisms must be avoided both in cold water and circulating hot water! The following applies: The temperature must be kept below 25°C at all points in cold water and above 55°C in hot water.

(N.B: For product solutions for temperature maintenance in hot water, see chapter Regulating valves.)

2.

Implementing a hygienically beneficial installation layout in cold water

In the design phase, a hygienically beneficial installation layout should be chosen, stagnation should be counteracted and, at the same time, it should be possible to keep the flushing volumes as low as possible.

Hygienically unsuitable: T-piece installation

This installation layout presents operators with an enormous challenge, because, in this case, drinking water hygiene depends on user behaviour, over which the operator has no control. Users usually take only as much water as they need at any given time, regardless of whether stagnation is avoided and drinking water temperatures are maintained. The stagnation in dead legs and the critical water temperatures that result from this are commonplace and force operators to carry out regular, ineffective and labour-intensive flushing measures. Temperature maintenance is more or less impossible with this system.

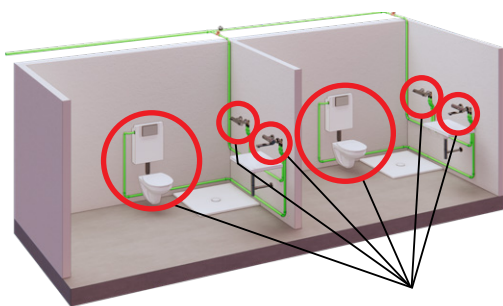

Multiple flushing points per bathroom



High risk of stagnation!



Permanent maintenance of temperature level not possible!

Hygienically partially suitable: serial installation

Serial installation will bring you one step closer to drinking water hygiene. In this case, the pipes are "looped through" in the bathrooms. At the end, a frequently used consumer, such as a hygiene flush box, is placed as a toilet solution.

The substantial disadvantages of this installation layout: Costly in terms of material, as a suitable flushing device must be provided in each bathroom. Despite this, temperature in cold water can only be maintained with great difficulty. The user would frequently be disturbed by the flush being unexpectedly triggered, including sometimes during the night. This is a detriment to comfort that may not be acceptable in hotels, hospitals or nursing homes, for instance.

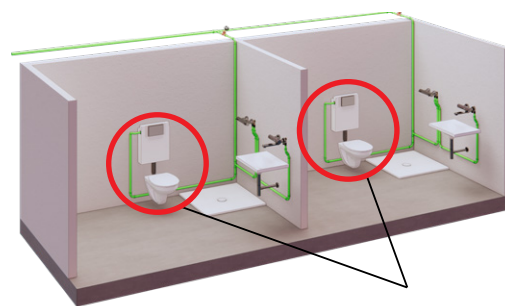

1 flush point per bathroom



No risk of stagnation!



BUT
Permanent maintenance of temperature level not possible!

Hygienically beneficial: ring installation with Flow-Splitters

The pipe of a serial installation is recirculated back to the distribution pipe after the last tapping point and connected via a Flow-Splitter which operates according to the Venturi principle. During on-going operation, water is exchanged in this way even in bathrooms where no water is taken.

The ring installation with Flow-Splitters effectively prevents stagnation with only one automatic flushing device at the end of the floor, taking into account economic and sustainability concerns. In this way, every stakeholder, from the designer to the plumber and operator, and all the way to the end user, is offered maximum safety and security.

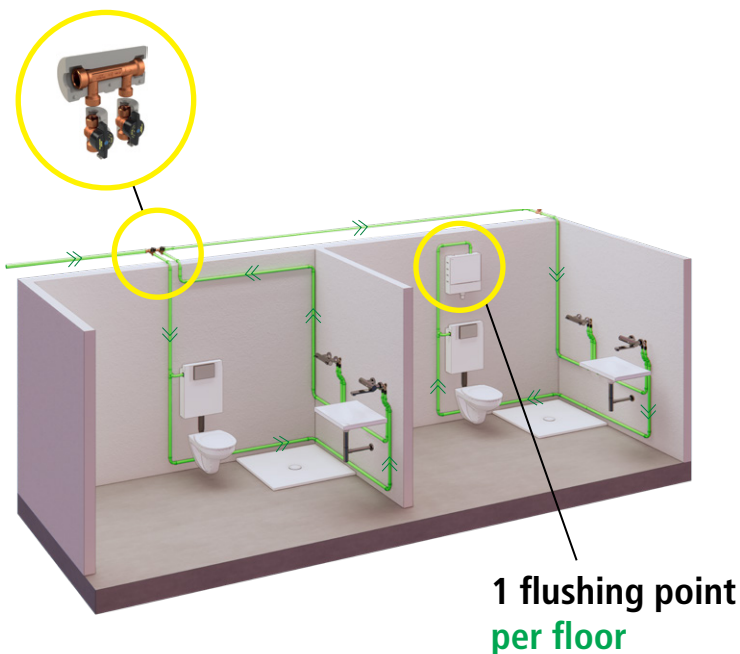

No risk of stagnation!



It is possible to constantly maintain the temperature level, as flushing measures take place unnoticed by the user.



KHS Flow-Splitter unit,
Figure 650 02

KHS Flow-Splitter -dynamic-

Functions

Due to the minimal pressure difference, the main volume flow is divided into a loop volume flow and a through volume flow by means of the venturi valve. The dynamic KHS Flow-Splitter is able to achieve a maximum flow through the connected loops even with very small volume flows in the distribution pipe/riser.

The drive is effected by the removal of water downstream of the KHS Flow-Splitter. The entire water content of the loop pipe is exchanged until immediately before the tapping points, stagnation and possible bacterial growth are avoided, and the drinking water temperature is kept low.

Benefits at a glance

- // Produces up to 100 water exchanges in bathrooms through downstream draw-offs every day by means of forced flow
- // Natural requirements lead to an up to 5K lower temperature level up to each bathroom
- // Noiseless water exchange in bathroom until immediately before each tapping point
- // Flexible with changes of use
- // Flush multiple bathrooms via one flushing point

3.

Elimination of errors in frequent water exchange

If stagnation occurs in some areas of the installation, for example due to lack of or change in the actually planned use, the required water exchange can be restored by using suitable automated flushing devices.

Automated flushing devices

The user behaviour may change during the operation of the building. Examples of this include seasonal low occupancy in a hotel, unused wings in a hospital, holiday homes with temporary in-occupancy and school holidays. This means that water extraction is no longer taking place as originally planned. In such cases, the intended operation can be restored through automated forced withdrawals via suitable flushing devices. A distinction needs to be made between normal drinking water installations and installations with special requirements, for example transferring ex-

tinguishing water, where large amounts of water must be provided when needed in a short amount of time. KEMPER offers a suitable product solution for each use case.

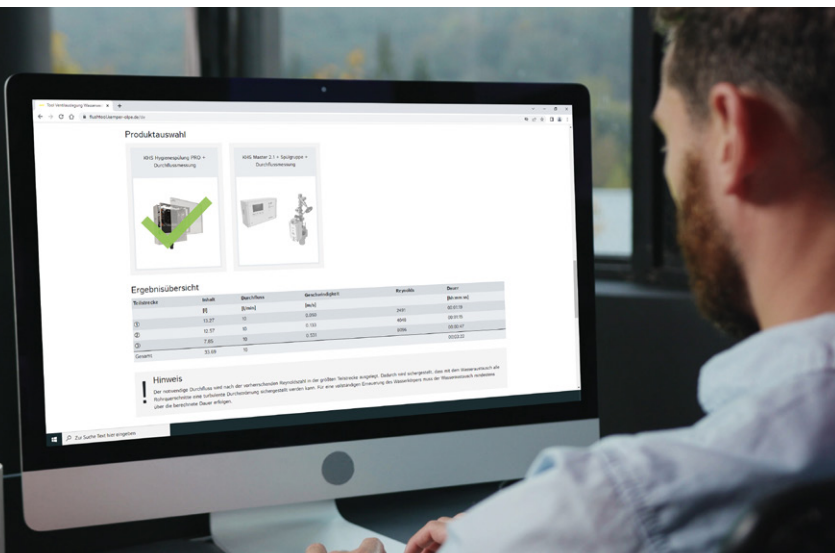

HANDY TIP!



Plumbing experts can use the KEMPER Flushtool to quickly and easily design flushing technology in line with the relevant standards – even for drinking water installations with an extinguishing water transfer system.

flushtool.kemper-olpe.com/en



Product solution 1: KHS Hygiene Flush Boxes – control via a controller concept that is optimal for the building.

KHS Hygiene Flush Boxes can be used to control the intervals, time, volumes, temperature and use of water exchanges. The PRO, PURE and LITE models let you select the optimal controller concept for the type of building use. Only the scope of function which is needed for the building in question will be selected. Effective flushing measures are also optimised economically, regardless of whether they are intended for small or large buildings

or areas of use without any device-specific controls

KHS Hygiene Flush Boxes can be surface-mounted or flush-mounted without additional accessories. Thanks to the innovative housing concept, all versions of the Hygiene Flush Box can be either flush-mounted so that they integrate almost invisibly into the wall structure or elegantly surface-mounted on the wall.

KHS Hygiene Flush Boxes also set the standards for sound-proofing: The controlled water exchange is ultra-quiet.

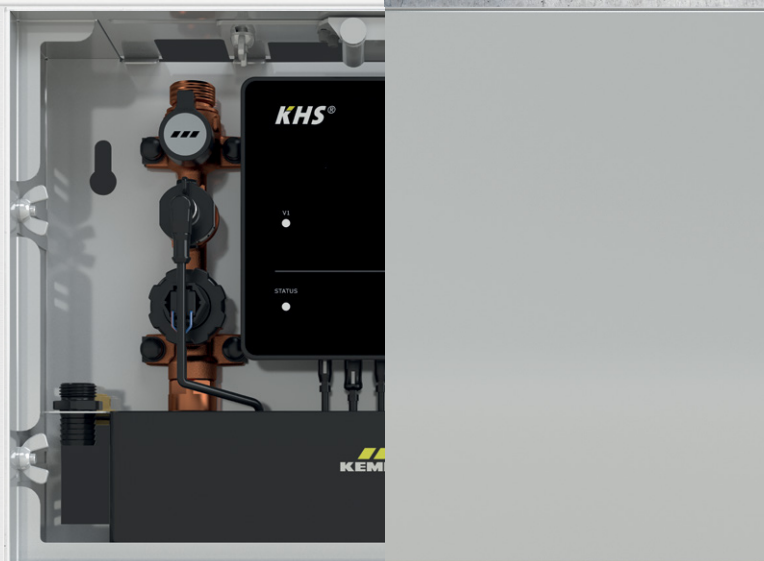

KEMPER

More information about KHS Hygiene Flush Boxes can be found at:

www.hygieneflushbox.com



Hygiene Flush Box PRO,
Figure 689 03 008

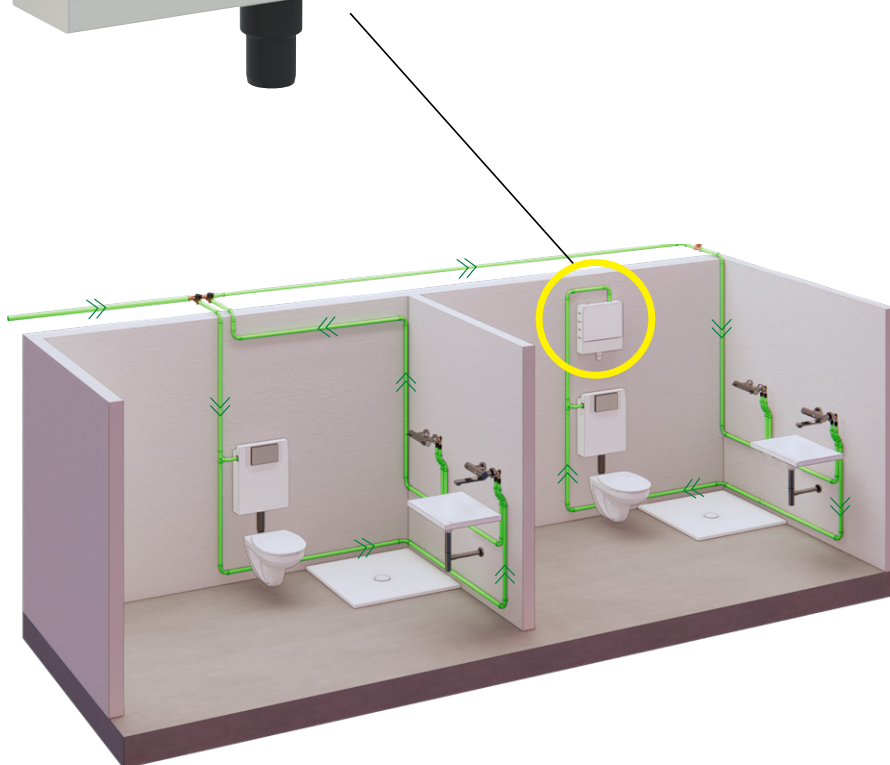

Product features

- // Ensures intended use through automatically triggered water exchanges
- // Ultra-quiet water exchanges even for comfort-oriented areas (e.g. hotel room)
- // For installation in all installation situations (flush- or surface-mounted)
- // Digital commissioning and maintenance assistant
- // Analysis and log readout via WLAN and USB
- // Incorporation into BMS (BACnet and Modbus) via Hygiene System KHS



Application area

Large buildings in particular require customised flushing strategies. The PRO version offers a particularly extensive list of options. Its potential areas of use include nursing homes, care homes and hospitals.



KHS Hygiene Flush Box PRO

Functionality

- // Seven timers for customised flushing strategies in particularly hygiene-sensitive buildings
- // Controls interval, time, volume, temperature and use of flushing
- // Convenient and safe operation via WLAN (can be switched off) using the latest Access Point Technology
- // Up to 100,000 event entries to verify use as intended
- // Analysis and log readout via WLAN and USB
- // Flushing process management provides savings potentials and suggests improvements
- // Networking of up to 60 Hygiene Flush Boxes possible



Application area

For compliance with the intended use in accordance with basic normative requirements through time-controlled interval flushes. Pure is particularly recommended for schools and nurseries.



KHS Hygiene Flush Box PURE

Functionality

- // Interval-controlled flushing
- // Commissioned in under a minute with 4 x PRESS
- // Up to 100,000 event entries to verify intended use (readout via USB)
- // Automatic detection and checking of all functional components
- // Optional upgrade to PRO



Application area

The Hygiene Flush Box LITE was designed for building requirements where a manufacturer flushing logic is expressly not desired, for example in the case of integration in a building automation system/BMS.



KHS Hygiene Flush Box LITE

Functionality

- // No integrated controller logic
- // Own control for direct connection to building automation systems/BMS

Product solution 2: KHS Flush Point with CONTROL-PLUS

The KHS Flush Point allows for automatically triggered, turbulent water exchange in drinking water pipes **up to DN 100** (for flow limiter 20 l/min).

Four different variants can ensure the intended use in combination with KHS system controls or alternatively a building management system (BMS). The time, temperature and volume parameters of the water exchange can be controlled.

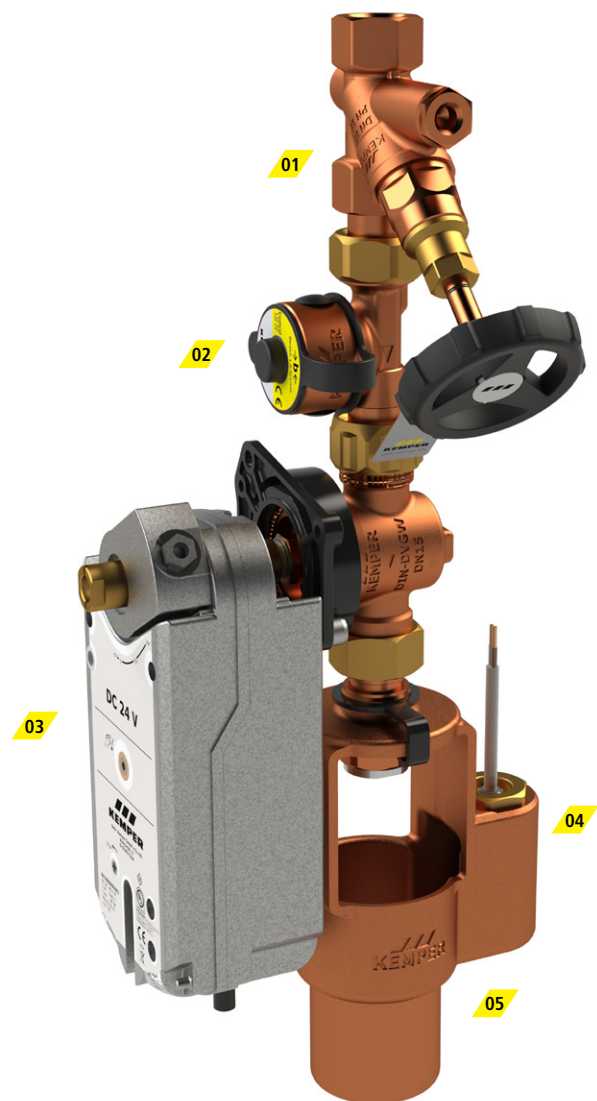

- 01 Maintenance cut-off with WESER free-flow stop valve
- 02 CONTROL-PLUS flow and temperature measurement valve sensor to precisely determine flushing volumes
- 03 Flushing valve with spring return actuator for water-hammer-free water exchanges
- 04 Flow limiter for pressure-independent flow limitation
- 05 DN 50 free drain with overflow monitoring to protect the drinking water according to EN 17177

KHS Flush Point with CONTROL-PLUS,
Figure 684 05



KHS Mini Control System



KHS MASTER 2.1 Mini Control System
Figure 686 02 008

KHS SLAVE Mini Control System
Figure 686 02 006

The KHS Master 2.1 Mini Control System is used to control and evaluate all connected actuators and sensors of the drinking water installations at a central point. The control system logs all events and operational data to verify the intended use and therefore ensuring transparency in the drinking water installation. Water can be exchanged in such a way that compliance with drinking water hygiene in all types of buildings is ensured.

Up to 62 SLAVE Control Systems can be connected to the MASTER/SLAVE system via CAN bus. Hygiene Flush Boxes can also be integrated in the system. The control system can be operated via the internal display or the web interface.

The planned water exchanges are saved in a flush log which includes flow, media temperature and flush duration.

Benefits at a glance

- // Reliability as water exchange processes are documented
- // It is possible to read out the flushing logs via USB stick
- // Convenient, web-based user interface

The building management system can also be connected to via the following protocols:

- // Modbus TCP/IP
- // BACnet IP
- // BACnet MS/TP

The connection allows access to data points that enable visualisation, evaluation and control of all flush valves and sensors connected via the MASTER/SLAVE system.



KHS BACnet Gateway L / XL
Figure 686 02 23 / 24

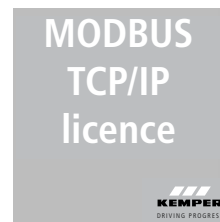

Modbus TCP/IP licence
Figure 993590

4.

Elimination of faults in cold water temperature maintenance

Preventative planning and a design with a hygienically beneficial installation type are therefore good conditions for complying with the intended use and maintaining drinking water hygiene in the building. Even a fault in frequent water exchange can be eliminated with suitable flushing devices which ensure automated forced withdrawals.

But what is to be done when frequent water exchange is insufficient to guarantee that temperature is constantly maintained in cold water?



INTERNAL HEAT LOADS

High heat loads in installation areas

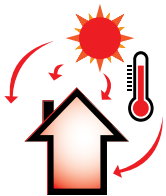

EXTERNAL HEAT LOADS

**High ambient air temperatures
Incoming main water temperatures**

Sources of danger: Temperature maintenance

In addition to preventing stagnation, temperature maintenance in cold and hot water is essential for maintaining drinking water hygiene. Lukewarm temperatures between 25°C and 50°C provide ideal breeding conditions for microorganisms. The cold water temperature must therefore be kept below 25°C in all pipe sections. However, external and internal heat loads can seriously hinder maintaining temperature in cold water.

Influence of external and internal heat loads

High external temperatures, high incoming main water temperatures (external heat loads) and heat sources such as hot water pipes of the building systems and components of the electrical and ventilation systems (internal heat loads) lead to the compartment air in the installation areas to continually heat up. Even with insulated pipes, cold drinking water can absorb this heat and reach hygienically critical temperatures in a short amount of time. In this context, laying cold and hot water lines in combined shafts is particularly problematic.

This is aggravated by the factor of climate change in which environmental and incoming main water temperatures are increased further, which increases how much the cold water temperature is raised by. Along with climate change, there is the problem of water shortage. The amount of water available will become increasingly limited in the future and should be used sustainably.

Economy and ecology

The usual solution to reduce the cold water temperature is to flush out the heated drinking water. However, considering external temperatures are dictated by the time of year, it is obvious that the situation comes to a head in the summer months in combination with the influence of climate change. Increasing outside temperatures lead to increased ambient air temperatures

in the building and also raise the incoming main temperature of the drinking water. As a result, the frequency of temperature-controlled flushing measures is increased dramatically. Enormous flushing amounts are used for these flushing measures which, despite these amounts, are no longer effective. A practical example of this:

Effect of external air temperature and ground temperatures on flushing volumes of a hospital with no air conditioning

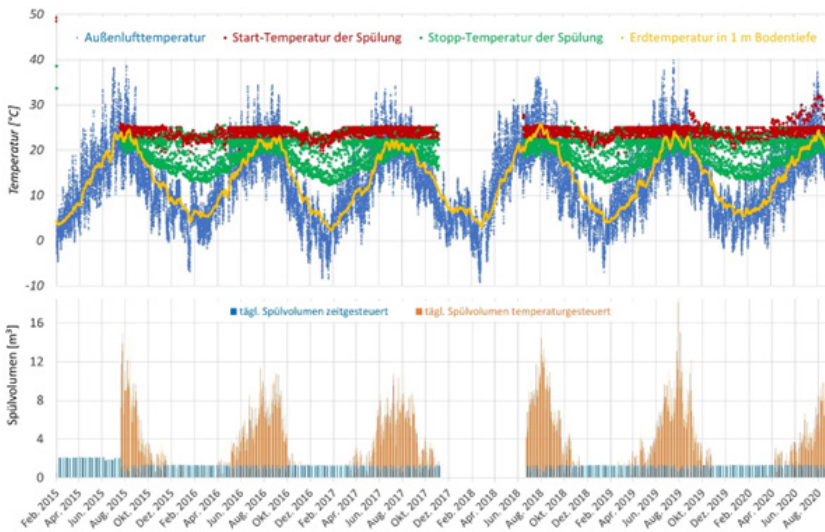

If the cold-water temperature of 24°C is exceeded, a system in the building will automatically trigger a flushing process which will end once 20°C has been reached. The aim of this measure is to keep the temperature of the cold water below the specified 25°C. In the winter months, the trigger temperature is rarely reached, which is reflected in the lack of flushing processes for temperature maintenance. However, in the summer months, high temperatures can cause a massive increase in flush volumes up to 16,000 l/day.

In many buildings, sustainable and economically justifiable protection against unacceptably high cold-water temperatures is only possible by cooling the cold drinking water in a circulation system (cold water circulation).



The solution: KHS CoolFlow

The use of KHS CoolFlow renders flushing measures for maintaining temperature in cold-water pipes superfluous. Using the cold-water cooler and special thermostatic balancing valves, KHS CoolFlow offers suitable components of a cold-water circulation system to keep the drinking water below 20°C. The drinking water is instantaneously cooled to precisely 15°C. The circulation volume flow is controlled in such a way that the recirculated drinking water measures 20°C. Active temperature maintenance

ensures that temperatures < 20°C can be reliably achieved even in buildings where thermal separation is only possible to a limited extent or where there are high heat loads in most installation areas. And without wasting the valuable resource that is drinking water! In combination with innovative Flow-Splitter technology, the circulation system can even be led up to the tapping points. In buildings where there are high heat loads, KHS CoolFlow will generally pay for itself within two years.

Sustainable and economical temperature maintenance – with KHS CoolFlow

- // Hygienically safe cold water temperatures against Legionella
- // Sustainable water use through minimisation of flushing volumes
- // Ensuring and documenting operation according to the intended use
- // Payback achievable in less than two years



KHS CoolFlow cold water balancing valve, Figure 615 0G 0150



KHS CoolFlow cold-water cooler, Figure 610 100 00

KHS CoolFlow cold water balancing valve – Automatic circulation balancing valve with integrated flushing function

3 functions – 1 valve

- // Balancing function
- // Flushing function
- // Stop function

100 % design reliability

A single control range for all applications simplifies sizing and guarantees reliability at all design and operation stages.

KHS CoolFlow cold-water cooler Flow-through drinking water cooler with integrated circulation pump

Huge output in a minimal space

With a space requirement of less than 0.5 m², buildings with a pipe length of up to 2000 m can be cooled to less than 20°C.

The all-rounder

An innovative storage solution allows it to be used without restriction in all existing and new process-coolers and chillers.

The complete package

The pre-assembled compact unit with integrated circulation pump already contains all necessary components for the drinking water side, is insulated so as to be diffusion-tight and is preconfigured.

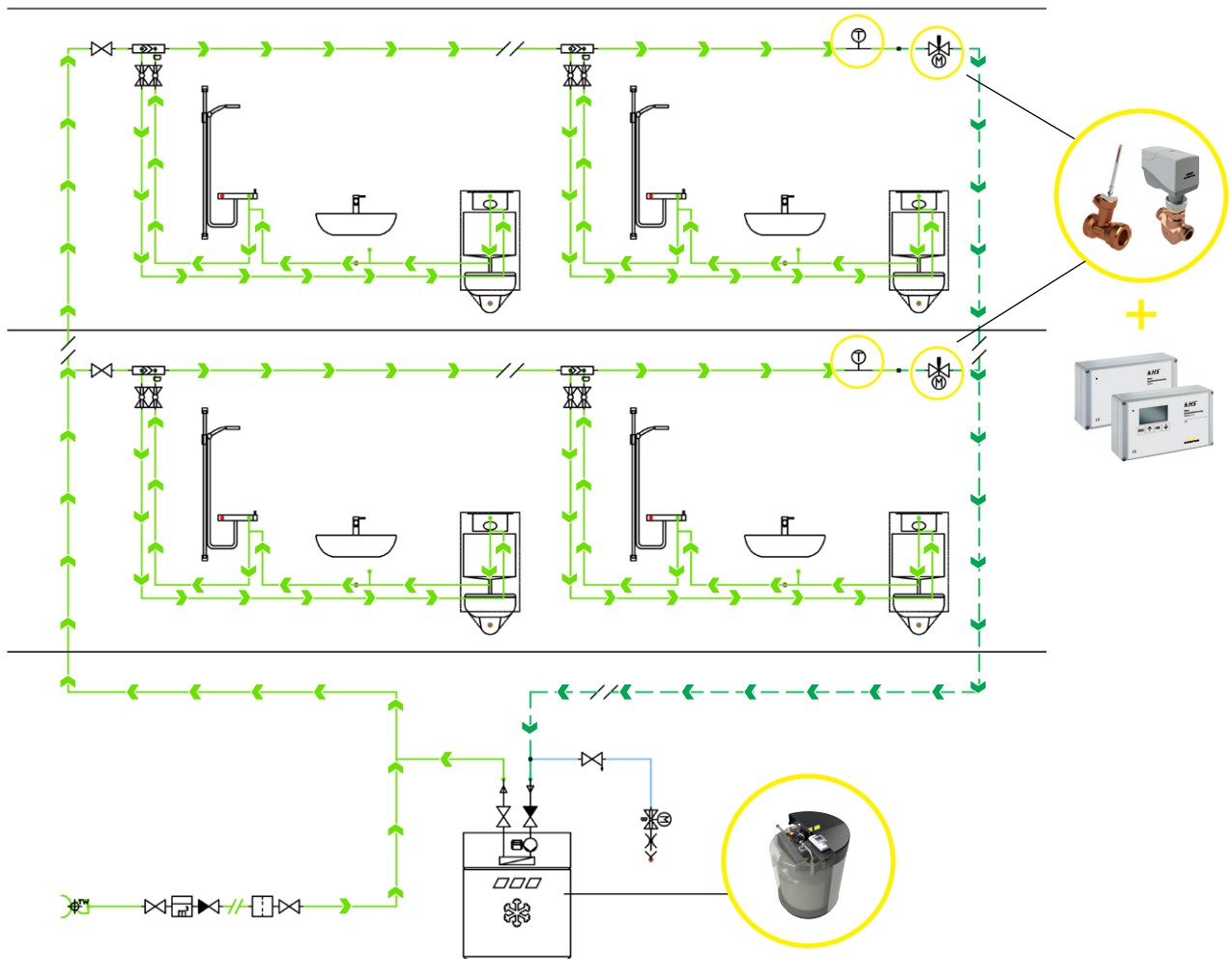

SUMMARY OF KEMPER HYGIENE SYSTEM KHS

As well as actively maintaining temperature, the KEMPER Hygiene System KHS also ensures the water exchange required by the relevant standards. Each building is considered holistically and individually. With product solutions tailored exactly to individual cases, the system ensures drinking water hygiene is optimally maintained while being conservative with resources, sustainable and economical.

More information about drinking water hygiene and KHS can be found at:



www.kemper-group.com/drinkingwaterhygiene

THERMAL SEPARATOR

HEAT TRANSMISSION RELIABLY AVOIDED AT MIXING TAPS

In circulation systems, the thermal separator reliably prevents heat transmission from the hot water to the mixing tap and the connected cold water. Thermal separation is achieved through the use of a thermal spacer between the hot water connection and integrated drop ear elbow.

In addition, the location of the drop ear elbow below the hot water connection brings about a thermal stratification in the medium, as no hot water moves down to the drop ear elbow on account of the density difference.



Thermography of two mixing taps that are connected to a circulation line:

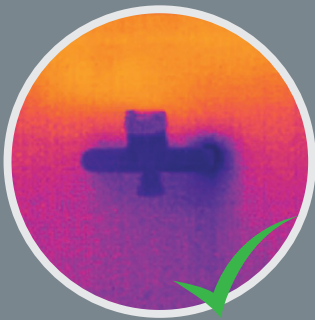

Mixing tap connected via a thermal separator.
(Temperature < 25°C)

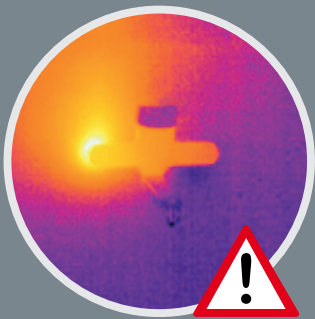

Mixing tap connected via double drop ear elbows.
(Temperature > 60°C)

Benefits at a glance:

- // Guaranteed temperatures < 25°C in the PWC drop ear elbow in pure circulation mode (60°C PWH-C)
- // 20% cost advantage over a comparable self-build
- // Universal installation for all conventional pre-wall systems and installation situations



Thermal separator

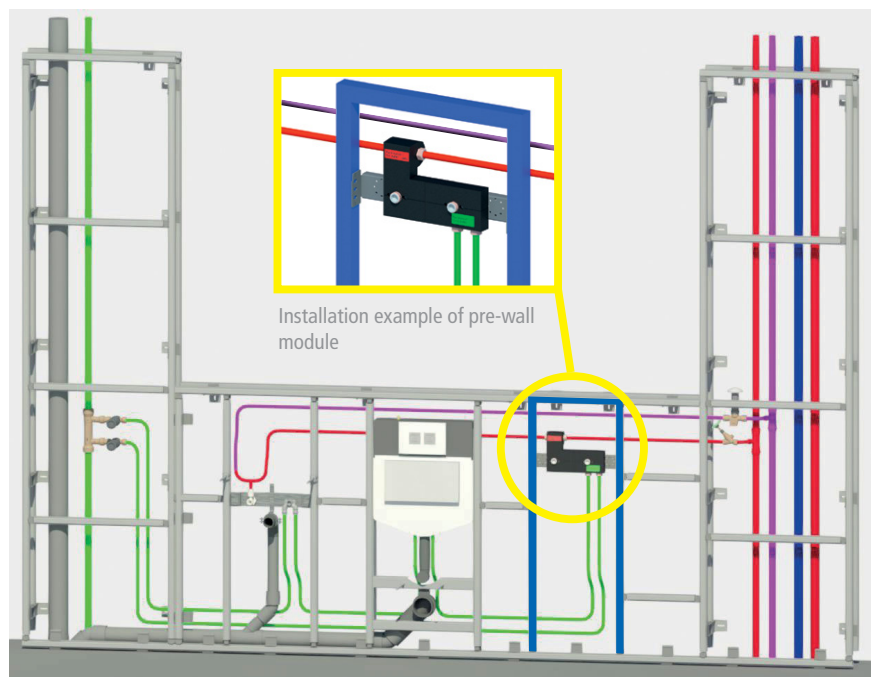
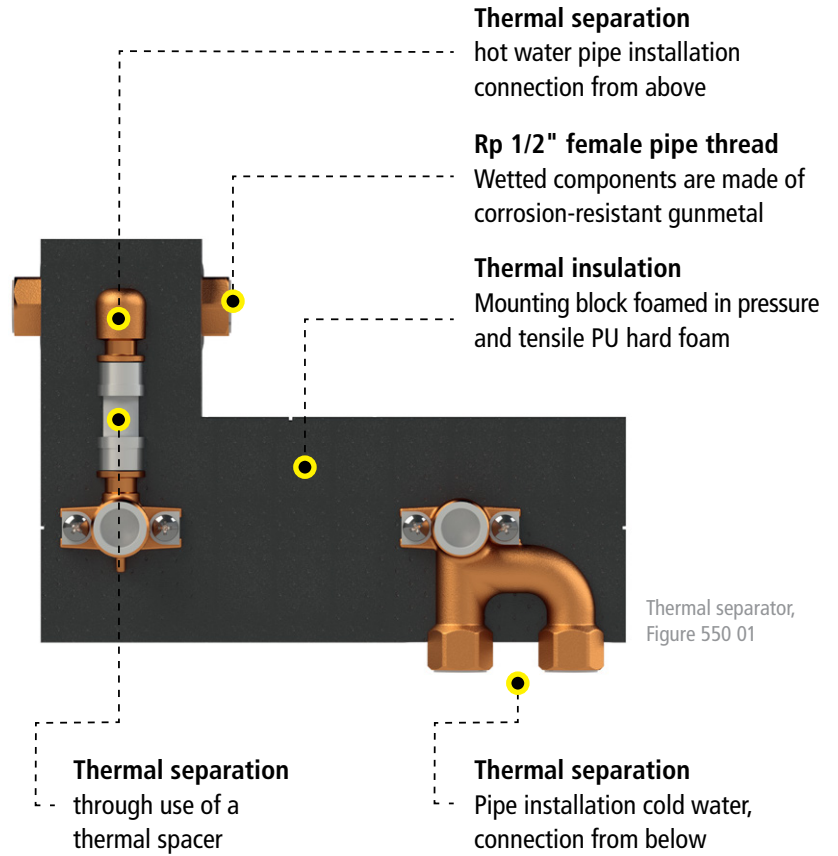

Optimal installation with separate shafts

THERMO- SYSTEM KTS

MANAGING ENERGY EFFICIENCY AND HYGIENE

Why choose instantaneous hot water heating?

Ensuring drinking water hygiene while maximising energy efficiency is currently one of the most significant challenges in building technology. It's essential to choose the right technology for the job that will allow you avoid risks that may affect drinking water hygiene while also enabling you to use energy as efficiently and sustainably as possible. KEMPER ThermoSystems KTS water heater provide innovative solutions for this very purpose. With outstanding performance data even at low forward flow temperatures, they're considerably

more effective as storage systems. This ensures that energy is used much more efficiently and the use of regenerative energy sources is more cost-effective. These solutions also provide significant advantages in terms of drinking water hygiene. Even at least water usage, the water content of the instant heating system is completely exchanged (e.g. only 3 litres for KTS water heater M). In contrast, storage systems in large properties often store volumes a thousand times larger, increasing the risk of stagnation.



Progress through KTS

With the increasing focus on harmonising the use of regenerative energy sources and maintaining drinking water hygiene, there are new and demanding requirements for drinking water heating systems. As a consequence, building technology components need to be better-performing and more flexible than ever. This also goes for their ability to communicate with a central building management system. All the while, time is increasingly of the essence in planning and execution. This means future systems need to be highly favourable in terms of sizing, assembly and commissioning.

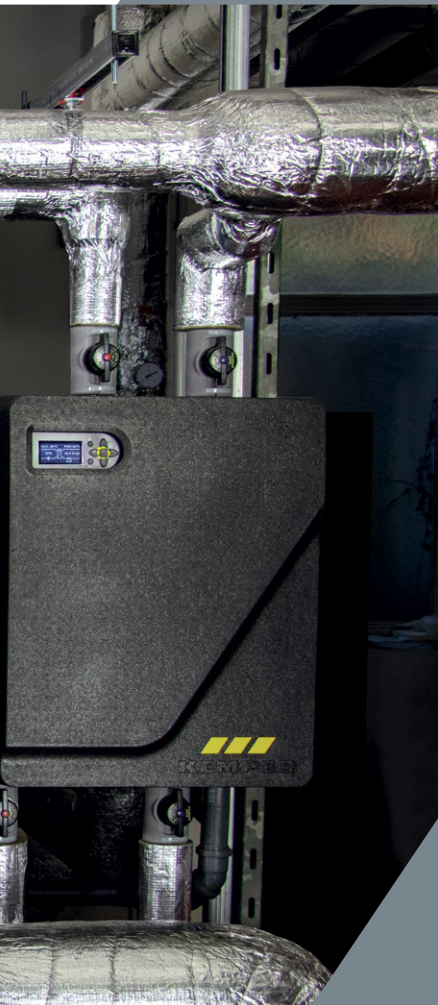

THE RESULTS OF CONSISTENT ONGOING DEVELOPMENT

With the new KTS water heater, ThermoSystem KTS has proved itself as a pioneer of domestic hot water heating systems. For almost any type of building or application, KTS can supply water with greater:

faster

more hygienic

more efficient

more innovative

Faster

// Assembly:

Included accessories such as safety equipment, additional sensors and a BMS interface allow you to save on additional assembly and cable costs. This cuts down on the usual assembly time by up to 50%.

// Commissioning:

A smart wizard lets you commission the system yourself in less than 60 seconds.

Dendrit *STUDIO*

Planning in just 3 steps

Planning KTS fresh water stations can be done more speedily with Dendrit *STUDIO* calculation software. Standard-compliant design takes place in just 3 steps

1. Select the type of application
2. Adapt the standard calculation parameters (e.g. flow temperature of the heat generator)
3. Issue the results documentation, including tender texts, material lists and installation plan

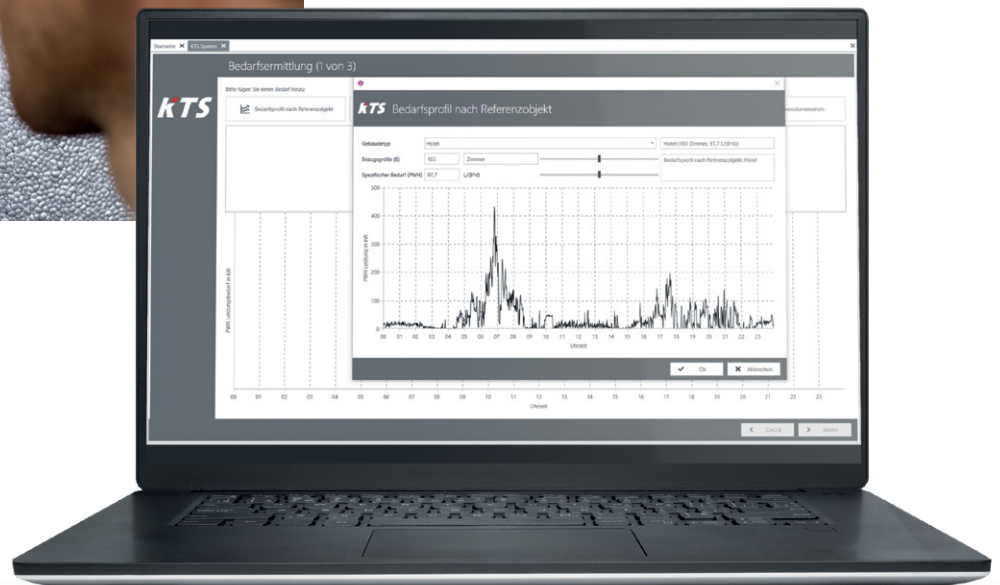

More hygienic

TIP

What's important for maintaining drinking water hygiene?

Maintaining temperature:

Microorganisms such as legionella multiply exponentially in lukewarm drinking water. So temperature ranges between 25°C and 55°C should be avoided.

Preventing stagnation:

If drinking water has stagnated in a system, this will give way to ambient temperatures that greatly impact hygiene. Additionally, metal substances from pipes and components will also accumulate. The water should therefore be replaced regularly!

This is why DIN 1988-200 and RKI guidelines state that the volume of heated drinking water to be stored should be kept to a minimum.

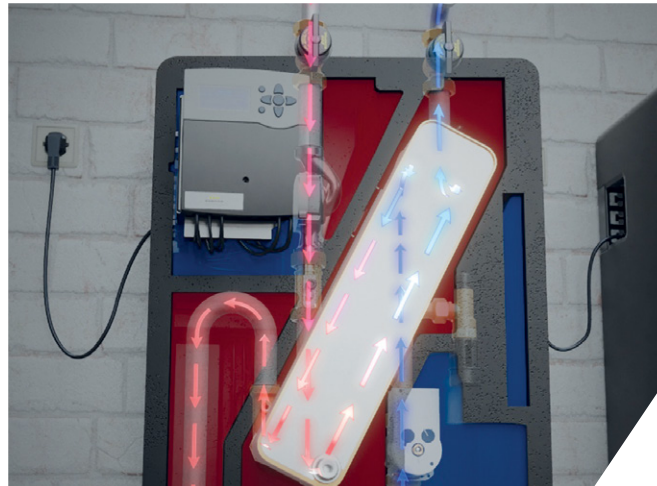

// **Strict separation of hot and cold areas:**

The insulation shell decouples the cold areas from the hot areas. This minimises the effects of the heat loads on the cold water that are detrimental to hygiene.

// **Cascade rotation:**

In phases with lower performance requirements, such as during circulation mode, often only one fresh water station is operated in cascade systems. Cascade rotation is engaged in order to prevent stagnation in the inactive fresh water stations. This causes all the heating units to automatically become active in alternating fashion so as to avoid hygiene risks.

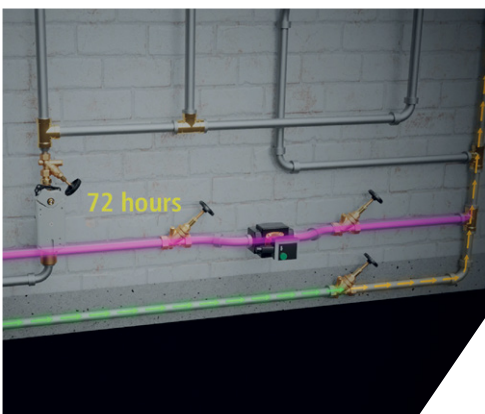

// **Avoiding stagnation in the cold-water pipe:**

During periods of non-usage (e.g. holidays or lockdown), the cold water in the pipes leading to the domestic hot water heating system often stagnates over several weeks, presenting a high potential risk to hygiene. This risk can be eliminated by the fresh water station's controller by triggering automated flushes thanks to a KHS Flush Point.

// **Hot water "on demand":**

KTS only heats drinking water when needed and only heats the amount that's actually needed. This does away with the need to store hot water and the risk of stagnation associated with this.

More efficient

// Energy savings of up to 10%:

Thanks to its powerful performance, the system only needs an over-temperature of 2K. So, hot drinking water can be output at 60°C even if the flow temperature is reduced down to 62°C. The KTS water heaters smart controller identifies unnecessarily high flow temperatures and indicates when it should be lowered.

// Get more efficiency out of heat pumps:

To make the use of the heat pumps noticeably more efficient, the flow temperature can be reduced.

// Power-to-Heat-ready:

The KTS Thermo-Tank Figure 965 is designed to be able to be retrofitted with heating elements. So any photovoltaic systems available can support the load of the heat buffer tank with solar energy.

// Store heat energy more efficiently:

Load and unload KTS ThermoTanks with low turbulence and mixing action thanks to specially developed baffle plates. This increases the energy efficiency of the heat energy storage.



More innovative



// Getting the most out of a pump's lifespan:

A patented chimney system ensures a constant air flow, whereby the performance-optimised pump is cooled effectively. The thermal load relief feature of the pump electronics allows you to get maximum efficiency throughout the pump's lifespan.

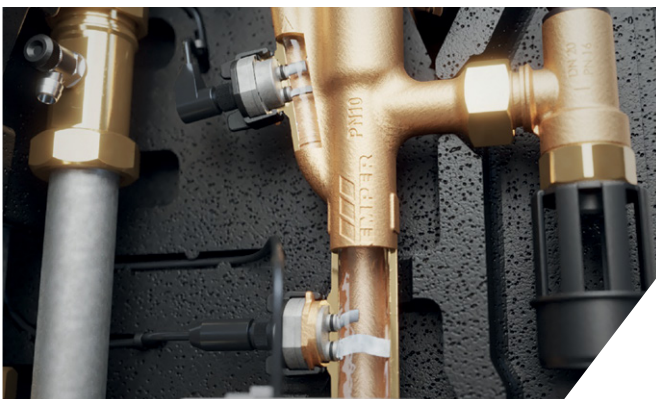

// Huge performance spectrum:

With a new, patented measuring track that responds 55% more effectively, you can register the smallest of requests even in larger systems. Starting from 1.6 l/min, the KTS water heater boasts an outstanding performance range. Thanks to its powerful components, it reaches a maximum hot water supply flow rate of 960 l/min.



// Integrated data logger:

According to the German Drinking Water Directive (Trinkwasserverordnung), operators are required to record and analyse operating states. To this end, the controller is equipped with a 16 GB data logger which records operating data over several years.

// Standard BMS compatibility:

The new KTS water heater, patented with an RS485 interface (modbus-RTU) at the factory, which allows it to directly communicate with an available building management system.

Product illustration and technical components



KTS water heater

- // Improves performance by over 200%
- // 50% less pressure loss
- // Response improved by 55%

01 Controller

- // Adaptive controller with high control quality
- // Standard BMS compatibility
- // Integrated data logger
- // Commissioning wizard
- // Optimisation function for lowering the flow temperature
- // Pump capacity automatically adapted on property-specific basis

02 Pump

- // Pulse width modulation
- // Anti-locking function

03 Gravity break

- // With ventilation feature and optimised response behaviour

04 PT 1000 temperature sensor

- // Quickly detect even the smallest of temperature changes directly in the medium





05 Sampling point

- // Drain valve as standard, sampling valve can be retrofitted

06 Pump chimney

- // Patented chimney system effectively cools the pump, achieving maximum efficiency throughout its lifespan
- // Pump electronics thermally separated from heated areas

07 Plate heat exchanger in different designs (copper solder and solid stainless steel)

- // Solid stainless steel for all levels drinking water quality according to Drinking Water Directive
- // Copper-soldered version up to 500 $\mu\text{S}/\text{cm el.}$ conductivity can be used

08 Measuring track in accordance with vortex principle

- // Innovative, patented measuring method from 1.6 l/min

09 Pressure relief valve

- // Integrated 10 bar membrane pressure relief valve

10 Quarter turn stop valve

- // Stop valve with actuator in cascade units for automatically executing cascade rotation
- // Individual devices are put into and taken out of the operating mode according to demand so as to balance the capacity of all cascade units

11 Insulation shell

- // Hot and cold areas strictly separated, minimising effects of heat loads on cold water detrimental to hygiene

KTS product video





KTS fresh water station

Technical data and accessories

	M station	L station
PWH removal flow rate ¹⁾	1.6 l/min - 75 l/min	1.6 l/min - 120 l/min
PWH temperature	30 - 70°C	30 - 70°C
Thermal disinfection	70 - 90°C	70 - 90°C
Max. performance ¹⁾	262 kW	418 kW
Dimensions H1 x L1 x D1	749 mm x 550 mm x 388 mm	749 mm x 550 mm x 388 mm

¹⁾ Values are based on storage temperature of 80°C and hot water temperature of 60°C

	Copper soldered M station	Copper soldered L station	Solid stainless steel M station	Solid stainless steel L station
single station	9152010100	9153010100	9252010100	9253010100
Two stage cascade	9152000200	9153000200	9252000200	9253000200
Three stage cascade	9152000300	9153000300	9252000300	9253000300
Four stage cascade	9152000400	9153000400	9252000400	9253000400
Five stage cascade	9152000500	9153000500	9252000500	9253000500



**Fresh water station
temperature sensor set**

Part no. 9160202100



KHS Flush Point 230 V

Part no. 6840401500



Gunmetal sampling valve

Part no. 1870000600



**BACnet gateway for
fresh water station**

Part no. 9160202200



**3-way valve,
DN 32 to DN 50**

Part no.	DN 32	9160203200
	DN 40	9160204000
	DN 50	9160205000



**3-way valve
DN 65 to DN 80**

Part no.	DN 65	9160206500
	DN 80	9160208000

KTS ThermoTank

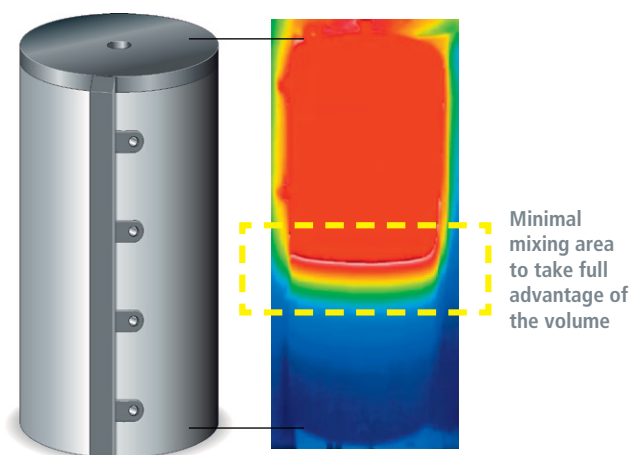

KTS ThermoTank

Thermographic image of the KTS ThermoTank

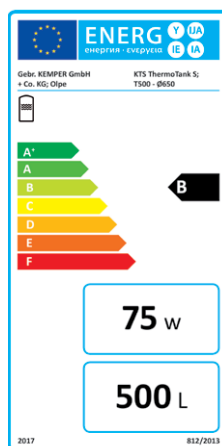

Energy efficiency label for KTS ThermoTank in accordance with EU Regulation 812/2013

Benefits at a glance

- // Enhanced energy storage innovations thanks to KEMPER's expertise
- // Load and unload KTS ThermoTanks with low turbulence and mixing action thanks to specially developed baffle plates.
- // Generous sizing and number of connections
- // Power-to-Heat-ready: heating elements can be integrated (Figure 965)

Technical data and accessories

KTS ThermoTank S buffer tank with baffle plate

Type	Volume (l)	Tilted size (mm)	Ø without insulation (mm)	Ø with insulation (mm)	PN 6, Figure 960 (part no.)	PN 10, Figure 970 (part no.)	PN 6 ²⁾ , Figure 965 (part no.)	Standby heat losses (W)	EEC ³⁾
T500 S	500	1700	650	850	9600050000	9700050000	9650050000	75	B
T850 S	850	2250	750	950	9600085000			101	C
T1000 S	1000	2250	790	990	9600100000	9700100000	9650100000	110	C
T1001 S ¹⁾	1000	2050	850	1050	9601100000			118	C
T1500 S	1500	2400	1000	1240	9600150000	9700150000		143	C
T2000 S	2000	2450	1100	1340	9600200000			160	C

¹⁾ like T1000 S, but overall height reduced by 210 mm.

²⁾ Buffer tank with three additional connections for electric heating elements with an offset arrangement.

³⁾ EEC = energy efficiency class according to EU Regulation No. 814/2013



KTS connection sets for ThermoTank

500 l

850 l / 1000 l

1500 l / 2000 l

When using a 3-way valve

9550501000

9550502000

9550503000

When not using a 3-way valve

9550601000

9550602000

9550603000

DENDRIT STUDIO

MODERN BUILDING TECHNOLOGY DESIGN – SMART AND RELIABLE

Dendrit *STUDIO* is a graphical calculation and design software for plumbing and heating. Thanks to the integrated project management feature, an unrestricted CAD interface and smart drawing tools and assistants, you can produce graphs for integrated calculations in no time at all.

For the plumbing industry there are extensive calculations available for drinking water and waste water connections as well as integrated

simulations for circulation and flushing technology. Through a data communications network, you can plan the heat load, the heating surface configuration and pipework calculation.

In the material extract, all masses of the calculations are available in detail across trades and can be transferred into all established business management systems.

Dendrit
Reliable Design



STUDIO
The system solution

Performance overview

Basic	Plumbing	Heating
 PROJECT MANAGEMENT	 DOMESTIC WATER INSTALLATIONS	 HEAT LOAD/ HEATING SURFACES
 DENCAD	 DOMESTIC WATER HEATING	 HEATING PIPE NETWORK
 WORKFLOW	 BUILDING DRAINAGE	
 RELIABLE PLANNING	-----	
 ANALYSES	<p>About Dendrit Dendrit Haustechnik-Software GmbH is a leading provider of system solutions in plumbing engineering calculations. This one-stop system solution is used by more than 20,000 users. The simulation of the circulation system and the KEMPER hygiene system KHS are particularly reliable for the planner when planning complex systems.</p>	
 HYDRAULICS REPORT	<p>Since January 2010, Dendrit Haustechnik-Software GmbH has been a subsidiary of the KEMPER Group. This association has allowed them to cooperate even more efficiently in recent years and, together, they intend to set more ambitious goals for the future.</p>	
 MATERIAL EXTRACT	<p>Strong partners Our many years of experience cooperating with industry partners, schools and scientific experts ensure our products are developed to be technically flawless and with foresight. High-performing, internationally renowned companies in the field of sanitation and home technology come together as a group to holistically, competently and reliably support design. All companies involved possess</p>	
 SERVICE	<p>unique product expertise and a strong market presence and are innovators. Their products are linked with one another through Dendrit <i>STUDIO</i>, which allows a hydraulics system to be illustrated in full in an end-to-end design.</p> <p>Their constant development and the technically flawless implementation of the normative changes are supported scientifically by the expertise of FH Münster, in the field of energy construction environment.</p> <p>Maxim The name Dendrit itself implies the fundamental idea of a graphical design concept. Dendrit (Greek) means tree or branching and thus refers to branching diagrams, the foundation of all designs and calculations for pipework in home technology. Due to increased requirements from standards and regulations regarding home technology design, considerably more work needs to go into designing. Keeping this amount of work to a minimum for the technical planner is what Dendrit's developers and engineers aspire to achieve.</p>	





WE'RE HERE FOR YOU!



Service contacts:

Do you need more information?

Find the right contact person on our website now:



