

DE	Montageanleitung Steuereinheit PRO PURE LITE für KHS Hygienespülung	»» 2
EN	Installation instructions MHI Unit for Hygiene Flush Box PRO PURE LITE controller	»» 3
FR	Instructions de montage Unité de commande PRO PURE LITE pour KHS Hygiene Flush Box	»» 4
IT	Istruzioni di montaggio Unità di comando PRO PURE LITE KHS Hygiene Flush Box	»» 5
NL	Montagehandleiding Besturing van de KHS Hygiene Flush Box PRO PURE LITE	»» 6



PRO
Fig. 689 04 012



PURE
Fig. 689 04 011



LITE
Fig. 689 04 013





Herstelleradresse

Gebr. Kemper GmbH + Co. KG
Harkortstraße 5
57462 Olpe
Tel.: +49 2761 891-0
Web: www.kemper-group.com

Kundendienst

Service-Hotline
Tel.: +49 2761 891 800
Mail: anwendungstechnik@kemper-group.com

Über diese Anleitung

Lesen Sie diese Anleitung vor Montagebeginn oder Gebrauch sorgfältig und folgen Sie den Anweisungen! Bewahren Sie die Anleitung zur späteren Verfügung auf!

Abbildungen in dieser Anleitung dienen dem grundsätzlichen Verständnis und können von der tatsächlichen Ausführung abweichen.

Haftung

Der Hersteller leistet keine Gewährleistung oder Haftung bei:

- Nichtbeachten dieser Anleitung.
- fehlerhaftem Einbau und/oder Gebrauch.
- eigenständiger Modifikation am Produkt.
- sonstiger, fehlerhafter Bedienung.

Sicherheitshinweise

Beachten und befolgen Sie die Sicherheitshinweise in der Anleitung. Das Nichtbeachten der Sicherheitshinweise kann zum Tod, zu Verletzungen oder zu Sachschäden führen.

Kennzeichnung wichtiger Warnhinweise:



Gefahr! Elektrischer Strom!

Kennzeichnet Gefahren, die schwere oder tödliche Verletzungen zur Folge haben können.



Warnung!

Kennzeichnet Gefahren, die zu Verletzungen, Sachschäden oder Verunreinigung des Trinkwassers führen können.



Hinweis!

Kennzeichnet Gefahren, die zu Schäden an der Anlage oder Funktionsstörungen führen können.



Gefahrenquellen

Gefahr! Elektrischer Strom!

Lebensgefahr durch elektrischen Strom!

Schalten Sie das System vor Arbeiten daran spannungsfrei.



Warnung!

Verletzungsgefahr durch unsachgemäße Montage!

Die Montage und Wartung darf nur durch eine Sanitärfachkraft erfolgen.



Warnung!

Gesundheitsgefahr durch Rückstände in Leitungen!

- Spülen Sie die Leitungen nach Montage und Wartung immer nach DIN EN 806-5 und VDI/DVGW 6023 (siehe Seite 10).



Manufacturer's address

Gebr. Kemper GmbH + Co. KG
Harkortstraße 5
57462 Olpe
Tel.: +49 2761 891-0
Web: www.kemper-group.com

After-sales service

Service hotline
Tel.: +49 2761 891 800
Email: anwendungstechnik@kemper-group.com

About this manual

Read this manual carefully before starting assembly, use and maintenance and follow the instructions! Retain the manual for later reference! Illustrations in this manual serve to aid basic understanding and may differ from the actual system configuration.

Liability

The manufacturer assumes no warranty or liability in case of:

- failure to follow these instructions
- incorrect installation and/or use
- unauthorised modification of the product
- other improper methods of operation.

Safety instructions

Be sure to read and follow the safety instructions in this manual. Failure to follow the safety instructions can result in injury or even death and in damage to property.

Labelling of important warning information:



Danger! Electricity!

Indicates hazards that may result in severe or fatal injury. .



Warning!

Indicates hazards that may result in injury, damage to property or contamination of drinking water.



Note!

Indicates hazards that may result in damage to the Hygiene Flush Box or malfunctions.



Source of danger

Danger! Electricity!

Danger of fatal electric shock!
Disconnect the system before carrying out work on it.



Warning!

Risk of injury due to improper installation!
Assembly and maintenance may only be carried out by a plumbing specialist.



Warning!

Health hazard from residues in feed pipes!

- Always flush the feed pipes in accordance with EN 806-5 and VDI/DVGW 6023 after assembly and maintenance work (see page 10).

Adresse du fabricant

Gebr. Kemper GmbH + Co. KG
 Harkortsstraße 5
 57462 Olpe
 Tél.: +49 2761 891-0
 Site Internet: www.kemper-group.com

Service après-vente

Ligne d'assistance téléphonique du service après-vente
 Tél.: +49 2761 891 800
 E-mail: anwendungstechnik@kemper-group.com

A propos de cette notice

Lisez soigneusement la notice avant le montage ou l'utilisation et respectez les instructions! Conservez la notice comme référence à l'avenir!
 Les illustrations de cette notice ont pour but de donner au lecteur une compréhension de base et peuvent diverger du modèle existant.

Responsabilité

Le fabricant n'assume aucune responsabilité ni aucune garantie:

- en cas de non-respect de cette notice,
- en cas d'installation et/ou d'utilisation incorrecte(s),
- en cas de modification autonome du produit et
- en cas de toute autre utilisation inappropriée.

Consignes de sécurité

Tenez compte et respectez impérativement les consignes de sécurité indiquées dans cette notice. Le non-respect des consignes de sécurité peut entraîner la mort, des blessures ou des dommages matériels.



Marquage des avertissements importants:



Danger! Courant électrique!
 Indique les dangers pouvant entraîner la mort ou des blessures graves.



Avertissement!
 Indique les dangers pouvant entraîner des blessures, des dégâts matériels ou une contamination de l'eau potable.



Remarque!
 Indique les dangers pouvant entraîner des détériorations sur le KHS Hygiene Flush Box ou des dysfonctionnements.



Sources de danger

Danger! Courant électrique!
 Danger de mort dû au courant électrique!
 Mettez systématiquement le système hors tension avant tous travaux à effectuer dessus.



Avertissement!
 Risque de blessures en cas de montage incorrect!
 Uniquement un spécialiste en sanitaire est autorisé à effectuer le montage et l'entretien.



Avertissement!
 Risque pour la santé dû aux résidus se trouvant dans les conduites!

- Rincez systématiquement les conduites après le montage et la maintenance conformément aux normes DIN EN 806-5 et VDI/DVGW 6023 (voir page 10).

Indirizzo del produttore

Gebr. Kemper GmbH + Co. KG
Harkortstraße 5
57462 Olpe
Tel.: +49 2761 891-0
Web: www.kemper-group.com

Servizio clienti

Service-Hotline
Tel.: +49 2761 891 800
E-mail: anwendungstechnik@kemper-group.com

Informazioni su queste istruzioni

Leggere con attenzione le presenti istruzioni prima di procedere al montaggio e all'utilizzo. Attenersi alle indicazioni fornite! Conservare le istruzioni per poterle consultare in seguito!

Le immagini riportate in queste istruzioni hanno lo scopo di agevolare la comprensione di base e possono differire dall'effettiva versione dell'impianto.

Responsabilità

Il produttore non fornisce alcuna garanzia né si assume alcuna responsabilità in caso di: mancata osservanza delle presenti istruzioni installazione e/o utilizzo errato modifica arbitraria del prodotto altro impiego non conforme.

Avvertenze di sicurezza

Rispettare e seguire scrupolosamente le avvertenze di sicurezza riportate in queste istruzioni. La mancata osservanza delle avvertenze di sicurezza può essere causa di morte, lesioni o danni materiali.



Indicatori delle avvertenze importanti:

**Pericolo!** Corrente elettrica!

Indica i pericoli che possono avere come conseguenza lesioni gravi o mortali.

**Attenzione!**

Indica i pericoli che possono essere causa di lesioni, danni materiali o inquinamento dell'acqua potabile.

**Nota!**

Indica i pericoli che possono causare danni all'impianto o malfunzionamenti.

**Fonti di pericolo**

Pericolo! Corrente elettrica!
Pericolo di morte per scossa elettrica!
Prima di qualunque intervento, scollegare il sistema dall'alimentazione elettrica

**Attenzione!**

Pericolo di lesioni per montaggio non corretto!
Montaggio e manutenzione devono essere eseguiti esclusivamente da personale specializzato in impianti sanitari.

**Attenzione!**

Rischi per la salute derivanti da depositi presenti nei condotti!

- Dopo gli interventi di montaggio e manutenzione sciacquare sempre i condotti conformemente alle norme DIN EN 806-5 e VDI/DVGW 6023 (vedi pagina 10).

Adres van de fabrikant

Gebr. Kemper GmbH + Co. KG
Harkortstraße 5
57462 Olpe
Tel.: +49 2761 891-0
Web: www.kemper-group.com

Technische dienst

Service hotline
Tel.: +49 2761 891 800
Mail: anwendungstechnik@kemper-group.com

Over deze handleiding

Lees deze handleiding zorgvuldig door voordat u begint met de installatie en het gebruik en volg de instructies op! Bewaar deze handleiding goed, zodat u haar later weer kunt raadplegen! Afbeeldingen in deze handleiding dienen voor het begrip van de werking en kunnen afwijken van de daadwerkelijke uitvoering.

Aansprakelijkheid

De fabrikant verleent geen garantie en stelt zich niet aansprakelijk bij:

- het negeren van deze handleiding
- incorrecte inbouw en/of incorrect gebruik
- eigenmachtige wijziging van het product
- andere foutieve bediening.

Veiligheidsinstructies

Neem de veiligheidsinstructies in de handleiding in acht en volg ze op. Het niet in acht nemen van de veiligheid-sinstructies kan leiden tot de dood, letsel of materiële schade.



Markering belangrijke waarschuwingen:



Gevaar! Elektrische stroom!
Markeert gevaren die ernstig of dodelijk letsel tot gevolg kunnen hebben.



Waarschuwing!
Markeert gevaren die tot letsel, materiële schade of verontreiniging van het drinkwater kunnen leiden.



Aanwijzing!
Markeert gevaren die tot schade aan de hygiënespoeler of tot functiestorings kunnen leiden.



Gevarenbronnen
Gevaar! Elektrische stroom!
Levensgevaar door elektrische stroom!
Schakel het systeem voor werkzaamheden eraan spanningsvrij.



Waarschuwing!
Letselgevaar door onvakkundige montage!
Montage mogen alleen door een loodgieter worden uitgevoerd.



Waarschuwing!
Gevaar voor de gezondheid door residuen in leidingen!

- Spoel de leidingen na montage en onderhoud altijd door volgens EN 806-5 en VDI/DVGW 6023 (zie pagina 10).



Durchflussmengenbegrenzer tauschen · Flow Limiter replacement ·
Remplacer le limiteur de débit · Sostituzione limitatore di flusso ·
Flowbegrenzer vervangen

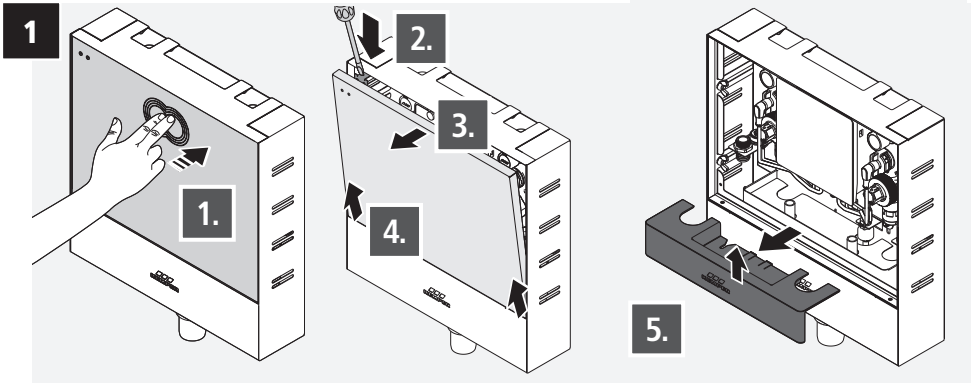

2



DE Gefahr! Elektrischer Strom!
Schalten Sie das System vor Arbeiten
daran spannungsfrei.

EN Danger! Electricity!
Disconnect the system before
carrying out work on it.

FR Danger! Courant électrique!
Mettez systématiquement le système
hors tension avant tous travaux à
effectuer dessus.

IT Pericolo! Corrente elettrica!
Prima di qualunque intervento, scol-
legare il sistema dall'alimentazione
elettrica.

NL Gevaar! Elektrische stroom!
Schakel het systeem uit voordat u
er aan gaat werken.

2.

DE Gegen Wiedereinschalten sichern!
EN Protect against restart!
FR Sécuriser contre une remise en marche!
IT Proteggere da una riaccensione!
NL Beveiliging tegen opnieuw inschakelen!

3.

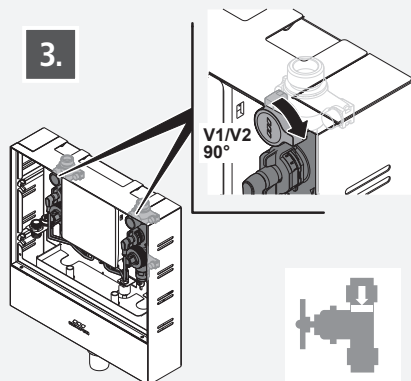



Durchflussmengenbegrenzer tauschen · Flow Limiter replacement · Remplacer le limiteur de débit · Sostituzione limitatore di flusso · Flowbegrenzer vervangen

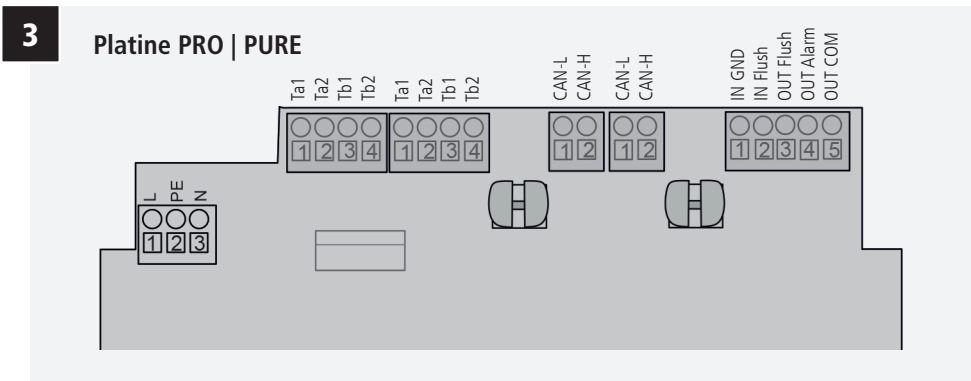
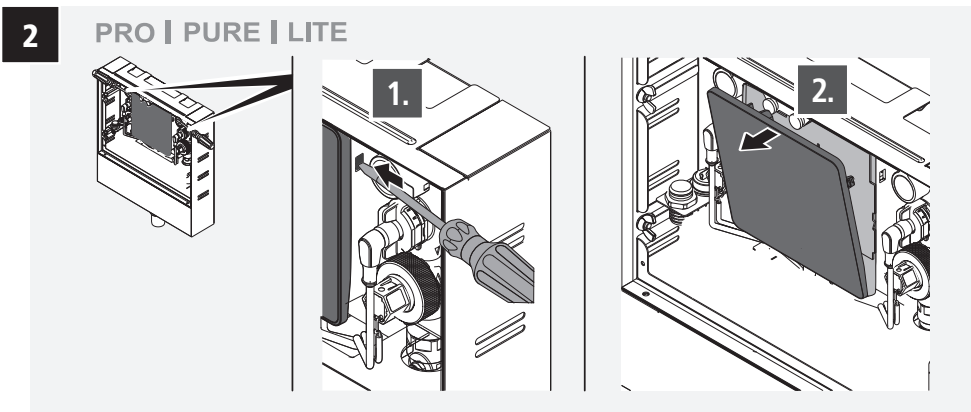
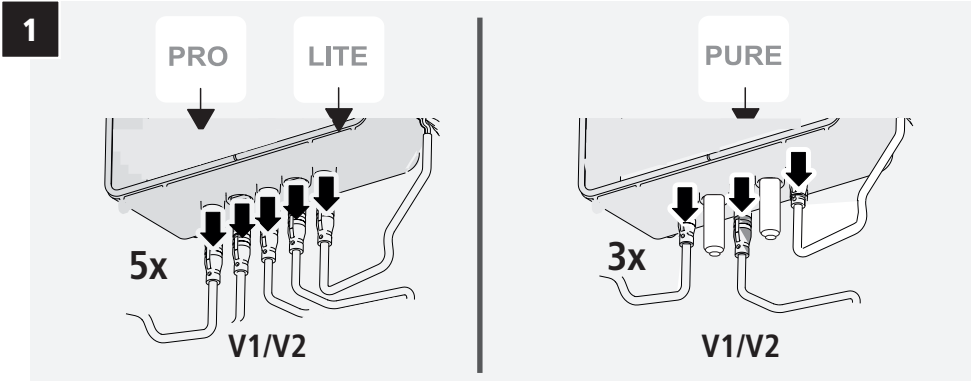

Platine LITE

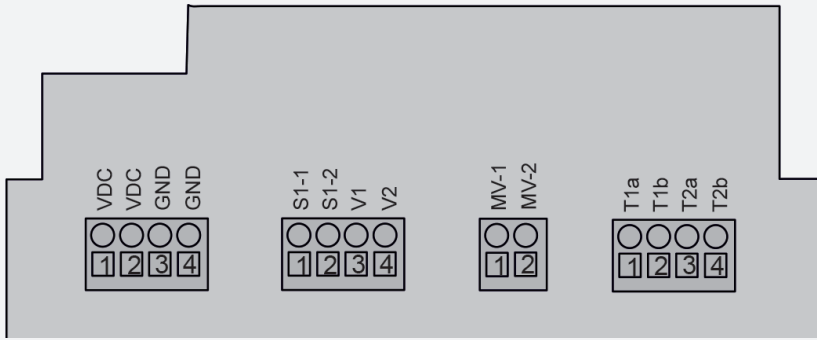

4 PRO PURE LITE

DE Beschriften Sie die Verkabelung oberhalb der Steuereinheit, bevor Sie die Kabelklemmen lösen. - Wichtig, für nachfolgendes Anschließen!

EN Label the cables above the HMI unit before loosening the cable clamps. It's important for later reconnection!

FR Étiqueter le câblage au-dessus de l'unité de commande avant de desserrer les serre-câbles. - Important pour la connexion ultérieure!

IT Etichettare il cablaggio sopra l'unità di comando prima di allentare i ferma cavi. - Importante per il collegamento successivo!

NL Label de bedrading boven de besturingseenheid voordat u de kabelklemmen losmaakt. - Belangrijk voor latere aansluiting!

5 PRO PURE LITE

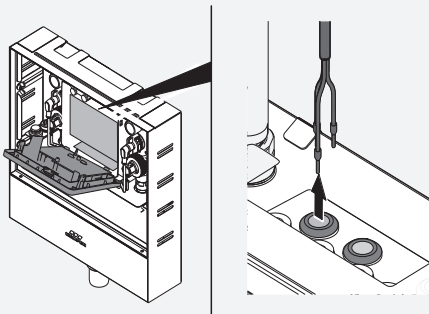

DE Lösen Sie alle auf der Platine montierten Kabel und ziehen Sie die Kabel aus der Steuereinheit heraus.

EN Detach all cables from the circuit board and pull out of HMI unit.

FR Desserrer tous les câbles montés sur le circuit imprimé et retirer les câbles de l'unité de commande.

IT Allentare tutti i cavi montati sulla scheda e tirare i cavi fuori dalla unità di comando.

NL Maak alle kabels los die op de printplaat zijn gemonteerd en trek de kabels uit de besturingseenheid.

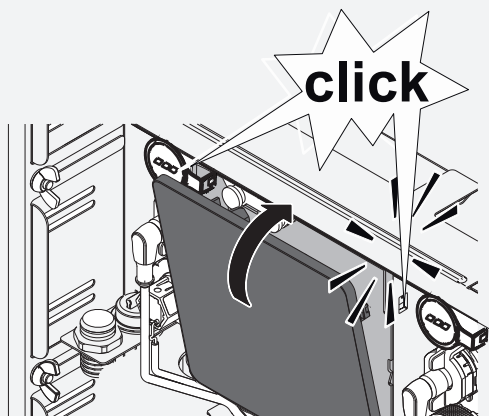
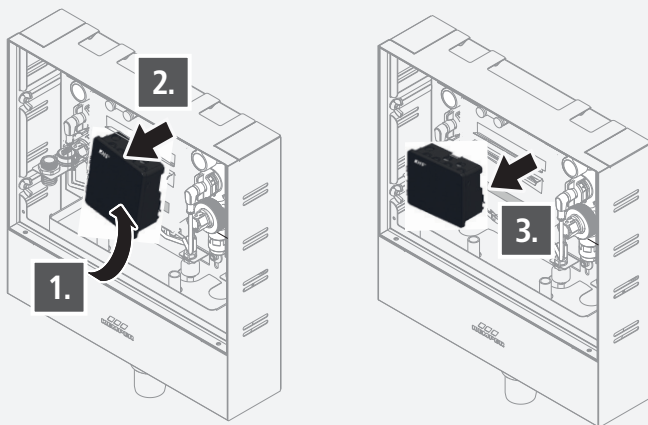
6**7**

- DE** Montierte Steuereinheit leicht anheben, nach vorne ziehen und von der Hutschiene entfernen.
- EN** Lift HMI slightly and pull slightly to remove from hat rail.
- FR** Soulever légèrement l'unité de commande installée, tirer-la vers l'avant et retirer-la du profilé.
- IT** Sollevare leggermente l'unità di comando installata, tirarla in avanti e rimuoverla dalla guida DIN.
- NL** De gemonteerde regeleenheid iets opheffen, naar voren trekken en van de bovenste rail verwijderen.

8

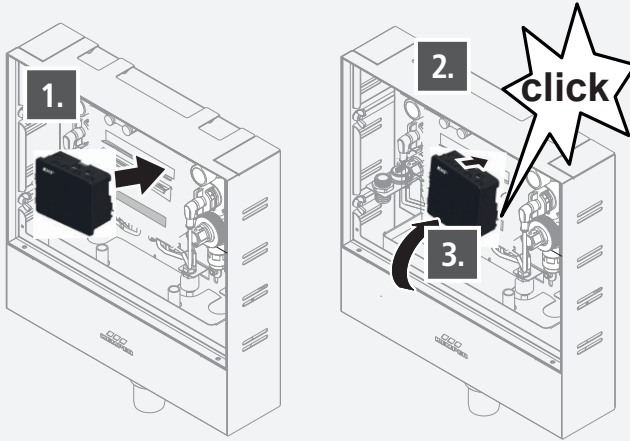

DE Neue Steuereinheit in Hutschiene einlegen und bis zum Click andrücken.

EN Place the new HMI on the hat rail an push till it snaps into position hearable.

FR Insérer la nouvelle unité de commande dans le profilé et appuyer dessus jusqu'au click.

IT Inserire la nuova unità di comando nella guida DIN e premerla finché non scatta in posizione.

NL Plaats de nieuwe bedieningseenheid in de bovenste geleider en druk deze aan tot hij vastklikt.

9

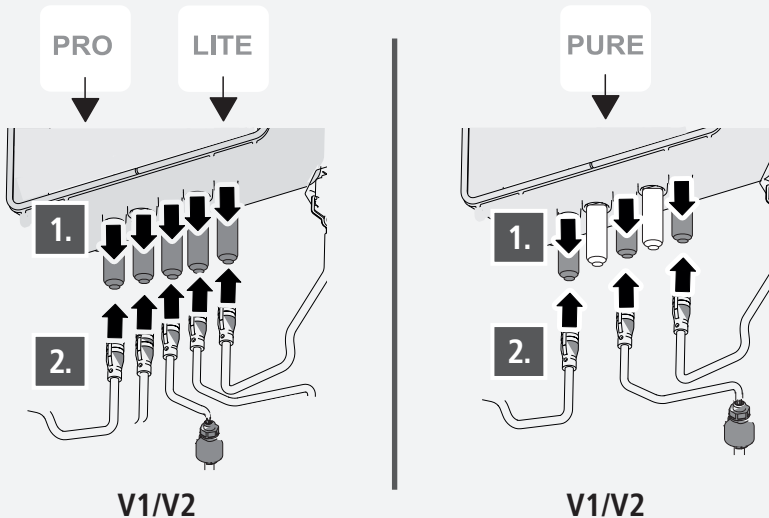

10

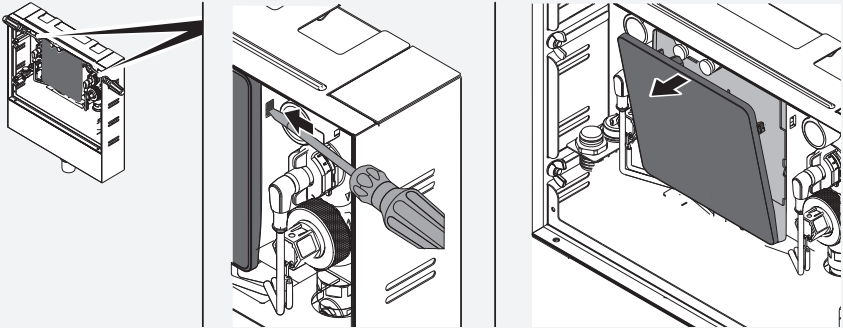

11

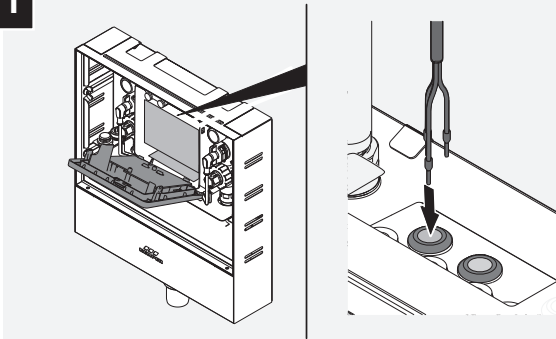

12

Platine PRO | PURE

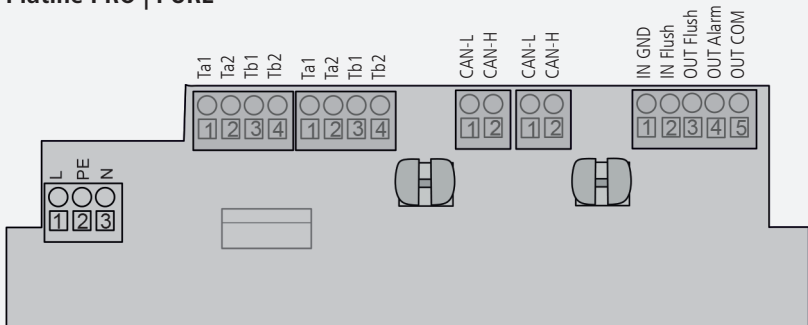

Platine LITE

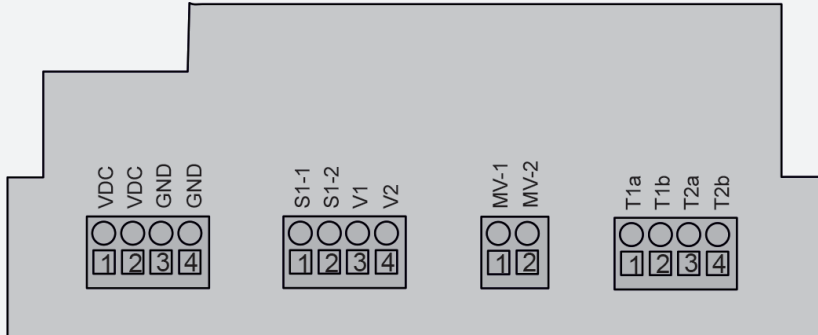

DE Nehmen Sie die ursprüngliche Verkabelung gemäß Ihren Notizen (siehe Punkt 4) vor.

EN Connect the cables back to the circuit board according labeling (see point 4).

FR Effectuer le câblage d'origine conformément à vos notes (voir point 4).

IT Eseguire il cablaggio originale secondo le vostre note (vedi punto 4).

NL Voer de oorspronkelijke bekabeling uit volgens uw eigen aantekeningen (zie punt 4).



Info

- Hilfestellung
- Support
- Assistance
- Assistenza
- Ondersteuning

P. 63-71



K410068903016-00

13

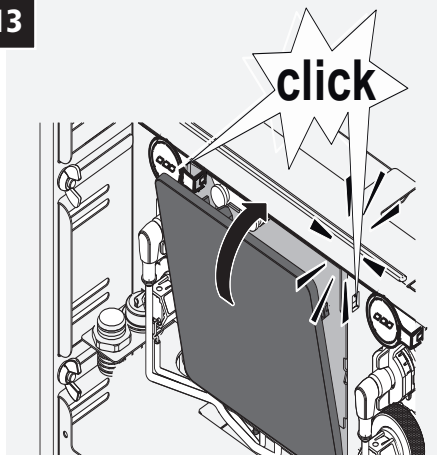

14



15

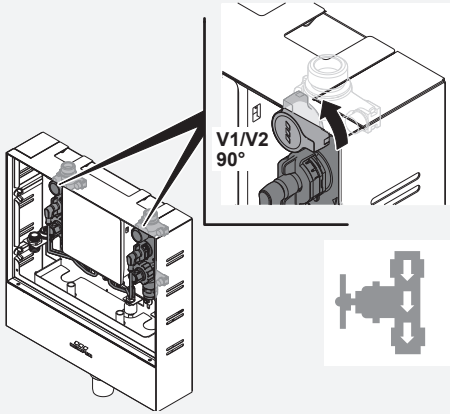

16

PRO | PURE



- DE Hinweis! Neue Seriennummer
- EN Note! New serial number
- FR Remarque! Nouveau numéro de série
- IT Nota! Nuovo numero di serie
- NL Aanwijzing! Nieuw serienummer

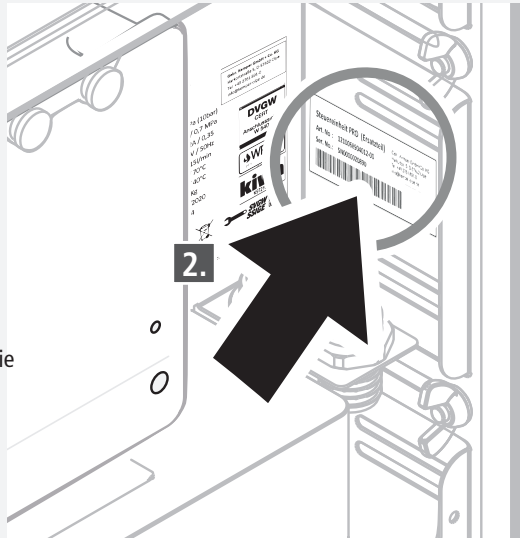

17



- DE **Info!** Nach dem Wechsel der Steuereinheit muss die Inbetriebnahme erneut durchgeführt werden.
- EN **Info!** Commissioning must be executed after exchange of HMI unit.
- FR **Info!** Après avoir changé l'unité de commande, la mise en service doit être effectuée à nouveau.
- IT **Info!** Dopo aver cambiato l'unità di comando la messa in servizio deve essere eseguita nuovamente.
- NL **Info!** Na het vervangen van de besturingseenheid, moet de inbedrijfstelling opnieuw worden uitgevoerd.

P. 77-79



K410068903016-00



18

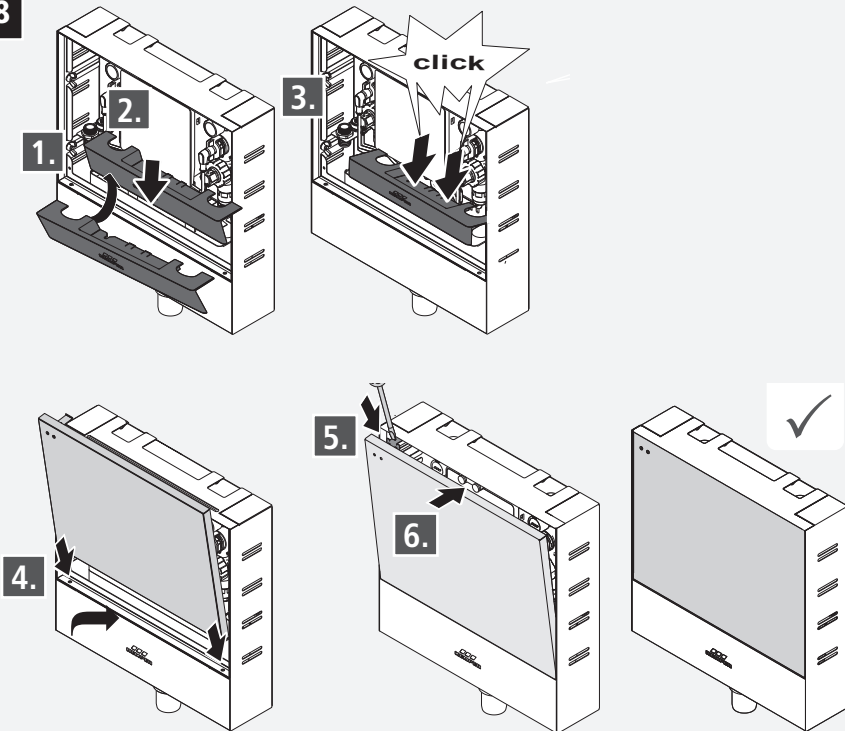

FORTSCHRITT MACHEN

Gebr. Kemper GmbH + Co. KG
Harkortstraße 5
D-57462 Olpe



Service-Hotline +49 2761 891-800
www.kemper-group.com
info@kemper-group.com

K410068903004-00 / 08.2024